

Assembly Equipment

Synflex Swaging Machine, Tools and Accessories	H2-3
Eaton Crimping Machine	H4-5
Hose Accessories	H5-8
O-Rings	H9-11
Crimp Die Charts	H12-15
Selection, Installation, and Maintenance.	H16-17
Assembly Instructions	H18-22



Synflex Swaging Machines

SST and Mark IX

Designed to Attach Synflex Permanent Fittings to Synflex Hose

- Synflex swaging equipment produces smooth, uniform fitting surfaces, without raised edges or ridges common in other fitting methods.
- Complete range of fitting swaging pushers and dies up to -16 size are ordered separately.



SST Portable Hand Swager

Part No.: 4530-01002

- Portable hand operated machine for field assembly
- Frame can be attached to bench vise or directly to a table with separate mounting bracket
- Weight: 3.6 kgs (8 lbs)



SST Portable Hand Swager Carrying Case

Part No.: 45J0-05600



Mark IX Swager

Part No.: 45J0-05600

- Fully automatic - opens dies to release completed assembly
- Fast actuation - capable of five-second cycle time
- Three power supply options for a broad range of production needs
- For heavy duty, continuous high-speed production needs the Mark IX can be equipped with a high capacity power unit (see option three below)
- Weight: 59.4 kgs (131 lbs)

Option 1 (Part No.: 4530-009S0)

1HP, 60Hz, 115/208/230V single-phase motor; medium duty

Option 2 (Part No.: 4530-009S1)

1HP, 60 Hz, 230/460V three-phase motor; medium duty

Option 3 - A & B (Part No.: 453C-00020 and Part No.: 4530-009S4)

- (A) Mark IX machine without standard power supply. Part No.: 4530-009S4
- (B) Commercial-duty hydraulic power unit with 5HP, three-phase 230/460V motor, five-gallon reservoir, 4.1 GPM displacement. Part No.: 453C-00020



Pushers

Pusher selection is based on fitting end design chosen from assembly. Pusher part numbers are listed in the fitting tables on pages H12-15.

Example:

To attach a -06 (3/8-inch) hose to a -06 female JIC/SAE 37° swivel fitting (90306-065500), use pusher part number 4599-FP015.



Dies

Swaging dies are applied in paired sets. Die selection is based on hose series and size. Die part numbers are listed in hose selection chart, page H12-15.

Example:

To attach fitting 90306-065500 to a 3130-06 hose, die part number 4540-306 is utilized.



Die and Pusher Storage Rack

Part No.: 45J0-03401

- Rack holds twelve pushers and eight dies
- 16-gauge welded steel frame
- Wall mount or bench top
- Dimensions: 19 inches wide; 22-1/2 inches high; extends 3 inches from mounting surface

Crimping Machines

FT 1380 and T-420

Aeroquip FT1380



The ProCrimp 1380 crimp machine from Eaton crimps all your hose needs up to and including -20 SAE100R12 hose styles and the popular MatchMate Plus hose and fittings program (shown with optional die holder kit FT1380-2-4). The ProCrimp 1380 is electronically controlled to give fast, accurate crimps the first time and every time you need a hose assembly. The electronic keypad is easy to adjust, with up to 10 programmable crimp settings. For hose styles and sizes used less frequently simply enter the 3 digit code of that hose.

Ordering Instructions

See page H12-15 for tooling information.

FT1380-115 115V crimp machine 50/60 Hz

FT1380-2-3 FT1330 to FT1380 Die Cage conversion kit — back plate, bolts and instructions necessary to convert an FT1330 die cage to an FT1380 die cage. Simply remove the FT1330 back plate and replace it with the new FT1380 back plate.

FT1380-2-4 Optional die holder kit — Kit includes 4 die holder plates each of which will hold 2 die cages. Holes are pre-drilled on base of ProCrimp machine to accept these 4 plates.

FT1380-4 Optional fitting backstop-kit includes backstop and 5/32" hex wrench. The backstop allows the 1380 to crimp PTFE hose and be utilized for a fitting locator to increase efficiency.

Electrical Requirements

USA: FT1380-115 standard machine uses 115V, 50/60 Hz, 1.5 hp

Brazil: FT1380-1-2 standard machine uses 230V, 50/60 Hz, 1.5 hp

Australia: FT1380-230 standard machine uses 230V, 50/60 Hz, 1.5 hp

Canada: FT1380-115 standard machine. Requires CSA (Canadian Standards Association) approval. The FT1380-115 is CSA approved and is so noted on the nameplate.

Weatherhead T-420



The Coll-O-Crimp Super I is a versatile machine ideal for your shop, factory, construction, and mine locations. Big capacity combined with lever-activated crimping gives you wide coverage and a quick and simple way to make factory-quality hose assemblies.

Capacity

3/16" I.D. 1 fiber braid through 1-1/4" 6 spiral hose*; for hose other than 4 and 6 spiral, conversion tooling is required.

*Will not crimp 4SP/6SP ends

Mounting

Bench or C-40X cabinet.

Size

22" high, 10" wide, 20-1/2" deep

Weight

210 lbs.

CAUTION

The Coll-O-Crimp power source has the pressure relief valve set at 4000 to 4200 PSI. Damage to the press will result if higher pressures are used and warranty will be voided.

T-420 • Coll-O-Crimp Super I Packages for Z Series

-4 thru -16 (no -10), one-wire and two-wire

Package Number	ET420-002	ET420-003
Power Source	220V	110V
Contents Press	T-420-1	T-420-1
Hose Assembly	T-410-22	T-410-22
Pump	T-421U	T-421U-110
Adapter Ring	T-420-25	T-420-25

Ordering Instructions

See page H12-15 for tooling information.

Consult Product Advisor for complete crimp die and proper spacer ring information. Contact Eaton for additional assembly machine options.

Hose Accessories

Overall Spring Guards and T-420 Continued

T-420-N • Coll-O-Crimp Super I - 220V Package T-420N-110 • Coll-O-Crimp Super I - 110V Package

Includes one each of the following (with respective pump):

Catalog Number	Description
T-420-1	Coll-O-Crimp Super I Press and T-420-M Instructions
T-421U or T-421U-110	220v or 110V Electric Pump
T-400-2C	'U' Series Collet – 1/4"
T-400-3C	'U' Series Collet – 3/8"
T-400-4C	'U' Series Collet – 1/2"
T-400-5C	'U' Series Collet – 3/4"
T-400-6C	'U' Series Collet – 1"
T-400-10	Spacer Ring – Black
T-400-11	Spacer Ring – Silver
T-400-62	Spacer Ring Yellow
T-410-22	36" Pump to Press Hose Assembly
T-420-25	Adapter Ring for T-400 Series Collets
T-420-4CN	430 'U' Series Collet – 1/2"
T-420-5CN	430 'U' Series Collet – 3/4"
T-420-6CN	430 'U' Series Collet – 1"

ET420-004 • Coll-O-Crimp I - 220V Package ET420-005 • Coll-O-Crimp I - 110V Package

Both Packages include the following (with respective pump):

Catalog Number	Description
T-420-1	Coll-O-Crimp Super I
T-421U or T-421U-110	220v or 110V Electric Pump
ET400DC-M150S	'Z' Series Collet – 1/4"
ET400DC-M195S	'Z' Series Collet – 3/8"
ET400DC-M230S	'Z' Series Collet – 1/2"
T-420-85C	'Z' Series Collet – 5/8"
T-420-86C	'Z' Series Collet – 3/4"
ET420DC-M380S	'Z' Series Collet – 1"
T-400-10	Spacer Ring – Black
T-400-62	Spacer Ring – Yellow
T-420-80R	Spacer Ring – Black/White
ET1000SR-M190D	Spacer Ring – Light Green
ET420SR-M255A	Spacer Ring – Black/Grey
ET420SR-M495A	Spacer Ring – Brown
T-410-22	36" Pump to Press Hose Assembly
T-420-25	Adapter Ring for T-400 Series Collets
T-420-4CN	430 'U' Series Collet – 1/2"
T-420-5CN	430 'U' Series Collet – 3/4"
T-420-6CN	430 'U' Series Collet – 1"
T-420-7CN	430 'U' Series Collet – 1-1/4"

Overall Spring Guards

- Abrasion protection and support
- Protects hose from kinking
- Order in multiples of 7.6 m (25 ft) lengths



Hose Part Number	Standard Length ft	Type 2 Part No.	Type 3 Part No.
3800-03, 3R30-03, 3130-03, 37AL-03	25	4521-50000	-
3800-04, 3R30-04, 3440-04, 3130-04, 3V10-03, 37AL-04, 30CT-04	25	4521-51000	4521-02000
3800-06, 3440-06, 34PW-06, 3130-06, 3130-05, 37AL-05, 37AL-06, 30CT-05, 30CT-06	25	4521-53000	4521-04000
3800-08, 3R30-08, 3440-08, 34PW-08, 3130-08, 37AL-08, 30CT-08	25	4521-54000	4521-05000
34PW-10, 3440-10, 3130-12	25	4521-88000	-
3R80-03	25	4521-83000	-
3V10-04, 3130-05	25	4521-84000	-
3R80-06	25	4521-58000	-
3R80-08	25	4521-59000	4521-10000
3R80-12	25	4521-60000	-
3R80-16	10	4521-61000	-
3R80-04	25	4521-57000	-

Hose Accessories

Hose Guards/Bend Restricters, Protective Sleeving

Hose and Spring Guards



- Fitting-to-hose interface protection
- Made from high-grade, spring steel wire
- Guards provide protection against hose kinking at fittings
- Spring-type guards hand screw to the fitting shell to form a single unit assembly

Hose Part Number	Part Number
3R30-04, 3800-04, 3130-04, 37AL-04, 30CT-04	4521-91005
3130-05, 37AL-05, 30CT-05	4521-90005
3R30-06, 3R80-04	4521-92005
3R30-03, 3800-03, 3130-03, 37AL-03	4521-AG004
3800-06, 3130-06, 37AL-06	4521-94005
30CT-06, 3R80-06	4521-AA005

Plastic Protective Coil Sleeve



- Fitting-to-hose interface protection
- A convenient and economical way to protect hose and tubing lines
- Can be installed after hose assembly is made
- Lightweight
- Order in multiples of 20-ft (6m) lengths.

Hose Part Number	Part Number
3130-02	4554-04000
3R30-03, 3800-03, 3130-03, 3630-03, 37AL-03	4554-06000
3R30-04, 3130-04, 3630-03, 37AL-04, 30CT-04	4554-07000
3R30-06, 3800-04, 3440-04, 34PW-04, 3130-05, 3R80-03, 37AL-05, 30CT-05	4554-08000
3440-06, 34PW-06, 3130-06, 3R80-04, 37AL-06, 30CT-06	4554-10000
3R30-08, 3800-06, 3130-08, 3R80-06, 37AL-08, 30CT-08	4554-12000
3800-08, 3440-08, 34PW-08, 3R80-08	4554-14000
3130-12, 3R80-12, 3440-10, 34PW-10, 3630-12	4554-16000
3440-12, 34PW-12	4554-19000
3R80-16, 3440-16, 34PW-16	4554-22000

Hose Accessories

Hose Guards/Bend Restricters (continued)

Vinyl Hose Guards

- Assembly abrasion protection and support
- Use when a non-metallic guard is required. Guard assembly may require the use of lubricant on the hose
- Available in 15.2m (50-ft) lengths
- Note: 4513-05 30m (100-ft) lengths



Hose Part Number	Part Number	Guard I.D.	Guard O.D.
3R30-04, 3440-04, 34PW-04, 3130-04, 3R80-03, 37AL-04, 30CT-04	4513-04000	9/16	13/16
3R30-06, 3440-06, 34PW-06, 3130-06, 3R80-04, 37AL-06, 30CT-06	4513-05000	11/16	1-1/16
3R80-06	4513-06000	15/16	1-13/14
3R80-08, 3800-08	4513-10000	15/16	1-5/16
3130-12, 3R80-12	4513-11000	1-3/16	1-11/16

Molded Black PVC Hose Guards

- Assembly abrasion protection and support
- Protects against wear when a stiffer, non-metal guard is preferred
- Hand-held use, keeps hose from kinking at fitting



Hose Part Number	Part Number	Guard I.D. A	Length L
30CT-04, 3R30-04, 3630-04, 3130-04, 3580-04, 3R80-03, 3800-04, 37AL-04	45J0-04801	.55	6.0
30CT-06, 3R30-06, 3630-06, 3130-06, 3580-06, 3R80-04, 3800-06, 37AL-06	45J0-04802	.69	7.0

Clamps

Plastic-covered clamps to secure hose



Hose Part Number	Part Number	bolt hose Size (in)
3130-02	45J0-00201	13/32
3130-03, 3630-03, 3800-03, 37AL-03	45J0-00202	13/32
3130-04, 3630-04, 3800-04, 37AL-04, 30CT-04	45J0-00204	13/32
3R80-03, 3130-05, 37AL-05, 30CT-05	45J0-00203	13/32
3R80-04	45J0-00205	13/32
3130-06, 3630-06, 3800-06, 37AL-06, 30CT-06	45J0-00206	13/32
3R80-06, 3130-08, 3630-08, 3800-08, 37AL-08, 30CT-08	45J0-00207	13/32
3R80-08	45J0-00208	13/32
3130-12	45J0-00209	13/32
3R80-12, 3630-12	45J0-00210	17/32
3R80-16	45J0-00212	17/32

GENERAL INFORMATION

HYDRAULIC HOSE

AIR & WATER HOSE & TUBING

TRUCK HOSE

AERQUIP/POLYON FITTINGS

AERQUIP/TTC FITTINGS

SYNPLEX FITTINGS

WEATHERHEAD (U & Z SERIES) FITTINGS

ASSEMBLY EQUIPMENT & INFORMATION

TECHNICAL DATA

Hose Assembly

Tools & Accessories

Hand-Held Hose Cutter

Part No. 4523-04006

- Handy tool for cutting Synflex hose 1/8-inch to 1/2-inch in diameter. Blades are replaceable. Vinyl cushioned grips.



Replacement Blade

Part No. 4523-04005

Swage Lubricant

Part No. 4545-01001

- Lubricant for use in the assembly of Synflex reusable and permanently attached stainless steel fittings.



Twin-Line Hose Separation Tool

Part No. 4574-01000

- Designed for separating Twin-Line hose



Replacement Blades

Part No. 4574-02000

(set of 10)

Dies

Part No. 4574-03000-XXX

Synflex De-Twiner Die Reference Chart (4574-03000-xxx)

Hose Product	Die* No.
3R30-03	027
3R30-04	003
3R30-06	010
3R30-08	013
3130-02	001
3130-03	002
3130-04	004
3130-05	008
3130-06	011
3130-08	013
3160-03	002
3160-04	004
3160-05	008
3160-06	011
3160-08	013

Hose Product	Die* No.
37AL-03	002
37AL-04	003
37AL-05	007
37AL-06	010
37AL-08	013
30CT-04	003
30CT-05	022
30CT-06	011
30CT-08	014
3360-03	002
3360-04	004
3360-05	023
3360-06	024
3360-08	025

Hose Product	Die* No.
3R80-04	009
3R80-06	012
3R80-08	015
3E80-04	009
3E80-06	012
3E80-08	015
3V10-03	005
3V10-04	016
3V10-06	017
3VEO-03	005
3VEO-04	016
3VEO-06	017

Hose Product	Die* No.
3840-03	018
3840-04	019
3840-06	020
3840-08	021
35NG-03	004
35NG-04	026
35NG-06	012
35NG-08	015
3V20-04	016
3V20-06	017
3251-08	006
31DW-04	005

Multi-Line Hose Separation Tool

Part No. 4573-00000

- Designed for Separation of tri-, quad- and five-line hose.

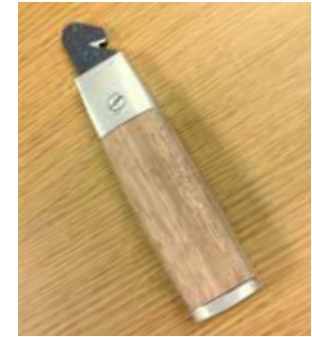

Replacement Blades

Part No. 4573-01000

Vise Blocks

Part No. 4504-00000

- 3/16-inch through 1/2-inch hose

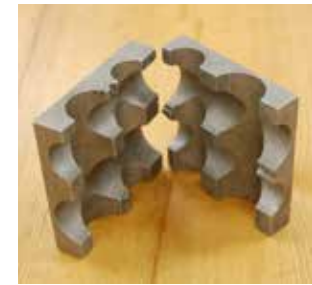

Part No. 4504-01000

- 3/4-inch and 1-inch hose. Used in making assemblies.

Insertion Depth Marker

Part No. 45J0-04603



O-Rings Seal Kit

FF16087-01

Includes metal box, o-rings for ORS -04 through -16, o-rings boss -04 through -16, 24 packages with twelve 90 durometer nitrile o-rings per package. Packages can be ordered individually by part number listed.



Connection	Size	12 O-ring Package Part No.	Individual O-Ring Part No.
ORS*	-04	FF10266-01-11	FF9446-11
ORS*	-06	FF10266-01-12	FF9446-12
ORS*	-08	FF10266-01-14	FF9446-14
ORS*	-10	FF10266-01-16	FF9446-16
ORS*	-12	FF10266-01-18	FF9446-18
ORS*	-16	FF10266-01-21	FF9446-21
O-Ring Boss	-04	FF10273-01-04	22617-4
O-Ring Boss	-05	FF10273-01-05	22617-5
O-Ring Boss	-06	FF10273-01-06	22617-6
O-Ring Boss	-08	FF10273-01-08	22617-8
O-Ring Boss	-10	FF10273-01-10	22617-10
O-Ring Boss	-12	FF10273-01-12	22617-12
O-Ring Boss	-16	FF10273-01-16	22617-16
O-Ring Boss	-32	FF10273-01-32	22617-32
Split Flange	-32	FF10266-01-228	FF9446-228

*For ORS o-ring kit order part number: FF10265-01, only includes ORS o-rings.

BSPP Bonded Seal for DIN 3852-2 Ports

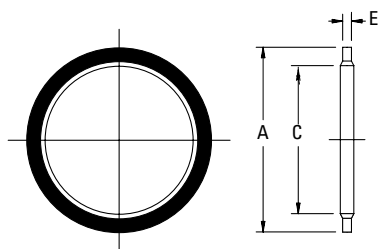

Bonded Seal Part Number	BSPP Thread Size	A Ref Inch	C Ref Inch	E Ref Inch
FF9895-02	1/8 - 28	0.625	0.403	0.080
FF9895-04	1/4 - 19	0.810	0.536	0.080
FF9895-06	3/8 - 19	0.937	0.675	0.080
FF9895-08	1/2 - 14	1.125	0.843	0.097
FF9895-10	5/8 - 14	1.250	0.920	0.097
FF9895-12	3/4 - 14	1.375	1.060	0.097
FF9895-16	1-11	1.685	1.329	0.133
FF9895-24	1 1/2 - 11	2.307	1.902	0.133
FF9895-32	2-11	2.875	2.380	0.133

Material: Steel with bonded Nitrile (Buna-N) seal.

GENERAL INFORMATION

HYDRAULIC HOSE

AIR & WATER HOSE & TUBING

TRUCK HOSE

AEROQUIP/POLYON FITTINGS

AEROQUIP/TTC FITTINGS

SYNFLEX FITTINGS

WEATHERHEAD (U & Z SERIES) FITTINGS

ASSEMBLY EQUIPMENT & INFORMATION

TECHNICAL DATA

Hose Accessories

Aeroquip O-Rings (continued)

Designating Separate SAE Boss O-Rings

To order Eaton o-rings separately without fittings specify the size and material by using the o-ring base number and dash size. The charts below offer a simple method to assure the correct o-ring for your application.

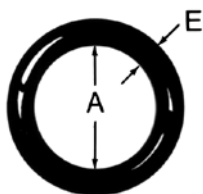

O-Ring Base No.	Material	Operating Temperature Range
22617 (Standard)	90 Durometer Buna-N Nitrile Rubber	-34°C to +121°C (-30°F to +250°F)
22033	EPR Ethylene Propylene Rubber	-55°C to +100°C (-65°F to +212°F)
22068	Viton* Fluoroelastomer	-25°C to +205°C (-15°F to +400°F)
22012	Buna-N, Low Temperature Nitrile Rubber	-55°C to +107°C (-65°F to +225°F)

O-Ring Dash Size	Tube Size	A		E	
		mm	in	mm	in
-4	-04 (1/4)	8,9	0.351	1,8	0.072
-6	-06 (3/8)	11,9	0.468	2,0	0.078
-8	-08 (1/2)	16,3	0.644	2,3	0.087
-10	-10 (5/8)	19,3	0.755	2,5	0.097
-12	-12 (3/4)	23,4	0.924	3,0	0.116
-16	-16 (1)	29,7	1.171	3,0	0.116

Designating Separate ORS O-Rings for Aeroquip

To order Eaton o-rings separately without fittings specify the size and material by using the o-ring designator and o-ring base number. The charts to the right offer a simple method to assure the correct o-ring for your application.

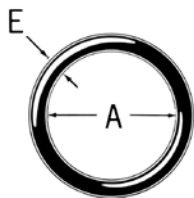

O-Ring Base No.	Material	Operating Temperature Range
22617 (Standard)	90 Durometer Buna-N Nitrile Rubber	-34°C to +121°C (-30°F to +250°F)
22033	EPR Ethylene Propylene Rubber	-55°C to +100°C (-65°F to +212°F)
22068	Viton* Fluoroelastomer	-25°C to +205°C (-15°F to +400°F)
22012	Buna-N, Low Temperature Nitrile Rubber	-55°C to +107°C (-65°F to +225°F)

O-Ring Size Designation	ORS Tube Size	A		E	
		mm	in	mm	in
-11	-04	7,6	0.301	1,8	0.07
-12	-06	9,2	0.364	1,8	0.07
-14	-08	12,4	0.489	1,8	0.07
-16	-10	15,6	0.614	1,8	0.07
-18	-12	18,8	0.739	1,8	0.07
-21	-16	23,5	0.926	1,8	0.07

O-ring, FOR-SEAL® Fittings

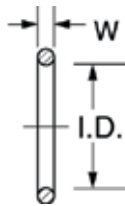

Material:
Buna N, 90 Durometer

Temperature Range:
-40°C to +121°C
(-40°F to +250°F)

Standard o-ring complies
with SAE specification
SAE J515 Type CH

Tube O.D.	Part Number	W	I.D.
1/4	4629x4	.070 ± .005	.301 ± .005
3/8	4629x6	.070 ± .005	.364 ± .005
1/2	4629x8	.070 ± .005	.489 ± .005
5/8	4629x10	.070 ± .005	.614 ± .005
3/4	4629x12	.070 ± .005	.739 ± .005
1	4629x16	.070 ± .006	.926 ± .006

Straight Thread O-ring

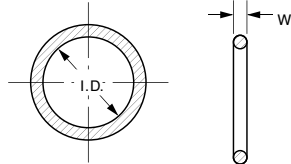

Material:
Buna N, 90 Duromete

Temperature Range:
-40°C to +121°C
(-40°F to +250°F)

Standard O-ring complies
with SAE specification
SAE J515 Type CH

Port Size	Part Number	W	I.D.
1/16	7629x1	.058	.185
1/8	7629x2	.064	.239
3/16	7629x3	.064	.301
1/4	7629x4	.072	.351
5/16	7629x5	.072	.414
3/8	7629x6	.078	.468
7/16	7629x7	.082	.530
1/2	7629x8	.087	.644
5/8	7629x10	.097	.755
3/4	7629x12	.116	.924
7/8	7629x14	.116	1.048
1	7629x16	.116	1.171

Crimp Die Chart

Aeroquip and Synflex

	Old Hose P/N	Old Fitting	Old Tooling	New Hose P/N	Qualified Fitting	Recommended Tooling
100R7	FC372-02	Polyon Fitting	-M090	3130-02	Polyon / FC5810	-M090
	FC372-03		-M120	3130-03	Polyon / FC5810	-M120
				3130-03	903 Series	-M120
	FC372-04		-M120	3130-04	Polyon / FC5810	-M120
				3130-04	903 Series	-M120
				3130-04	Global TTC	-M150
	FC372-05		-M150	3130-05	Polyon / FC5810	-M150
				3130-05	903 Series	-M150
	FC372-06		-M180	3130-06	Polyon / FC5810	-M180
				3130-06	903 Series	-M150
				3130-06	Global TTC	-M195
	FC372-08		M210	3130-08	Polyon / FC5810	-M210
				3130-08	903 Series	-M210
				3130-08	Global TTC	-M240
	FC372-12		-M280	3130-12	Polyon / FC5810	-M280
				3130-12	903 Series	-M240
				3130-12	Global TTC	-M295
	FC372-16		-M320	3130-16	Polyon / FC5810	-M320
				3130-16	Global TTC	-M390
	FC373-02		-M090	FC373-02	Polyon	-M090
FC373-03	-M120	37AL-03	Polyon / FC5810	-M120		
		37AL-03	903 Series	-M120		
FC373-04	-M120	37AL-04	Polyon / FC5810	-M120		
		37AL-04	903 Series	-M120		
FC373-05	-M150	37AL-05	Polyon / FC5810	-M150		
		37AL-05	903 Series	-M150		
FC373-06	-M180	37AL-06	Polyon / FC5810	-M180		
		37AL-06	903 Series	-M150		

GENERAL INFORMATION
 HYDRAULIC HOSE
 AIR & WATER HOSE & TUBING
 TRUCK HOSE
 AEROQUIP/POLYON FITTINGS
 AEROQUIP/TTC FITTINGS
 SYNIFLEX FITTINGS
 WEATHERHEAD (U & Z SERIES) FITTINGS
 ASSEMBLY EQUIPMENT & INFORMATION
 TECHNICAL DATA

Crimp Die Chart

Aeroquip and Synflex (continued)

	Old Hose P/N	Old Fitting	Old Tooling	New Hose P/N	Qualified Fitting	Recommended Tooling
100R7	FC373-08	Polyon Fitting	-M210	37AL-08	Polyon / FC5810	-M210
				37AL-08	903 Series	-M210
	FC373-12		-M280	3740-12	Polyon / FC5810	-M280
				3740-12	903 Series	-M240
				3740-12	Global TTC	-M320
	FC373-16		-M320	3740-16	Polyon / FC5810	-M320
3740-16		Global TTC		-M370		
100R8	FC374-03	Polyon Fitting	-M120	3R80-03	90H Series	-M120
				3800-03	903 Series	-M120
	FC374-04		-M120	3R80-04	90H Series	-M150
				3800-04	903 Series	-M120
	FC374-06		-M180	3R80-06	90H Series	-M180
				3R80-06	Global TTC	-M180
				3800-06	903 Series	-M150
	FC374-08		-M210	3R80-08	90H Series	-M210
				3R80-08	Global TTC	-M240
				3800-08	903 Series	-M210
	FC374-12		-M280	3R80-12	90H Series	-M280
				3R80-12	Global TTC	-M320
				3R80-16	Global TTC	-M370
	FC375-03		-M120	3E80-03	90H Series	-M120
	FC375-04		-M120	3E80-04	90H Series	-M150
	FC375-06		-M180	3E80-06	90H Series	-M180
				3E80-06	Global TTC	-M180
	FC375-08		-M210	3E80-08	90H Series	-M210
				3E80-08	Global TTC	-M240
	FC375-12		-M280	3E80-12	90H Series	-M280
3E80-12		Global TTC		-M320		
				3E80-16	Global TTC	-M370

GENERAL INFORMATION

HYDRAULIC HOSE

AIR & WATER HOSE & TUBING

TRUCK HOSE

AEROQUIP/POLYON FITTINGS

AEROQUIP/TTC FITTINGS

SYNFLEX FITTINGS

WEATHERHEAD (U & Z SERIES) FITTINGS

ASSEMBLY EQUIPMENT & INFORMATION

TECHNICAL DATA

Crimp Die Chart

Weatherhead and Synflex

GENERAL INFORMATION

HYDRAULIC HOSE

AIR & WATER HOSE & TUBING

TRUCK HOSE

AERODUPLICATION FITTINGS

AERODUPLICATION FITTINGS

SYNFLEX FITTINGS

WEATHERHEAD (U & Z SERIES) FITTINGS

ASSEMBLY EQUIPMENT & INFORMATION

TECHNICAL DATA

	Old Hose P/N	Old Fitting	Old Fitting Tooling	Old Fitting Spacer Ring	New Hose P/N	Qualified Fitting	New Tooling*	Spacer Ring*
100R7	H43603	"E"Series	T-400-113C	Black	3130-03	903 Series	M095S	Lt Green FSU
	H43604		T-400-31C	Black	3130-04	U Series	T-400-2C	Purple FSU
					3130-04	903 Series	T-400-2C	Black FSD
	H43605		T-400-32C	Black	3130-04	Z Series w/ Sleeve	T-400-121C	Yellow FSU
					3130-05	903 Series	M150S	Black FSD
	H43606		T-400-33C	Black	3130-05	903 Series	M150S	Black FSD
					3130-06	U Series	T-400-3C	Red FSU
	H43608		T-400-34C	Black	3130-06	903 Series	M150S	Lt Green FSU
					3130-06	Z Series w/ Sleeve	T-400-110C	Yellow FSU
	H43612		T-400-35C	Black	3130-08	U Series	T-400-4C	Purple FSU
					3130-08	903 Series	T-400-123C	Purple FSU
	H43616		T-400-36C	Black	3130-08	Z Series w/ Sleeve	T-400-42C	Black/Tan FSU
					3130-12	U Series	T-400-5C	Red FSU
	H43503		T-400-113C	Black	3130-12	903 Series	T-420-185C	Brown FSU
					3130-12	Z Series w/ Sleeve	M295S	Yellow FSU
	H43504		T-400-31C	Black	3130-16	Z Series w/ Sleeve	M390S	Black/Magenta FSU
	H43505		T-400-113C	Black	37AL-03	903 Series	M095S	Lt Green FSU
	H43506		T-400-32C	Black	37AL-04	903 Series	T-400-2C	Tan
					37AL-05	903 Series	M150S	Black/Tan FSD
	H43508		T-400-33C	Black	37AL-06	U Series	T-400-3C	Red FSU
37AL-06		903 Series			M150S	Lt Green FSU		
H43512	T-400-34C	Black	37AL-08	U Series	T-400-4C	Green FSU		
			37AL-08	903 Series	T-400-123C	Purple FSU		
			3740-12	U Series	T-400-5C	Green FSU		
H43516	T-400-35C	Black	3740-12	903 Series	T-440-85C	Brown FSU		
			3740-12	Z Series w/ Sleeve	M295S	Yellow FSU		
H43516	T-400-36C	Black	3740-16	U-Series	T-400-6C	Red FSU		
			3740-16	Z Series w/ Sleeve	M390S	Black/Magenta FSU		

*Consult Product Advisor for complete crimp die and proper spacer ring information.

Crimp Die Chart

Weatherhead and Synflex (continued)

	Old Hose P/N	Old Fitting	Old Fitting Tooling	Old Fitting Spacer Ring	New Hose P/N	Qualified Fitting	New Tooling*	Spacer Ring*
100R8	H33603	336E Fitting	T-400-120C	Black	3R80-03	336E / 90H Series	T-400-2C	Green
					3R80-03	903 Series	M095S	Lt. Green
	H33604		T-400-121C	Black	3R80-04	336E / 90H Series	M150S	Yellow
					3800-04	903 Series	T-400-121C	Magenta
	H33606		T-400-122C	Black	3R80-06	336E / 90H Series	M195S	Purple
					3R80-06	Z Series w/ Sleeve	M195S	Tan
					3R80-06	903 Series	M150S	Black
	H33608		T-400-123C	Black	3R80-08	336E / 90H Series	T-400-123C	Black
					3R80-08	Z Series w/ Sleeve	T-400-42C	Black/Tan
					3800-08	903 Series	T-400-41C	Yellow
	H33612		T-420-15C	N/A	3R80-12	336E / 90H Series	T-440-85C	Black/Orange
					3R80-12	Z Series w/ Sleeve	T-440-86C	Black/Magenta
	H33616		T-420-16C	N/A	3R80-16	Z Series w/ Sleeve	M380S	Black/Magenta
	H335-03		T-400-120C	Black	3E80-03	336E / 90H Series	T-400-2C	Green
	H335-04		T-400-121C	Black	3E80-04	336E / 90H Series	M150S	Yellow
	H335-06		T-400-122C	Black	3E80-06	336E / 90H Series	M195S	Purple
					3E80-06	Z Series w/ Sleeve	M195S	Tan
	H335-08		T-400-123C	Black	3E80-08	336E / 90H Series	T-400-123C	Black
					3E80-08	Z Series w/ Sleeve	T-400-42C	Black/Tan
	H335-12		T-420-15C	X	3E80-12	336E / 90H Series	T-440-85C	Black/Orange
3E80-12		Z Series w/ Sleeve			T-440-86C	Black/Magenta		
H335-16	T-420-16C	X	3E80-16	Z Series w/ Sleeve	M380S	Black/Magenta		

*Consult Product Advisor for complete crimp die and proper spacer ring information.

GENERAL INFORMATION

HYDRAULIC HOSE

AIR & WATER HOSE & TUBING

TRUCK HOSE

AEROQUIP/POLYON FITTINGS

AEROQUIP/TTC FITTINGS

SYNFLEX FITTINGS

WEATHERHEAD (U & Z SERIES) FITTINGS

ASSEMBLY EQUIPMENT & INFORMATION

TECHNICAL DATA

Selection, Installation and Maintenance of Synflex Hose and Assemblies

Proper hose selection, installation and maintenance practices should be followed to ensure that hose and hose assemblies have long life and operate safely. Failure to consider these practices could result in unplanned down-time, damage or injury. The general industry practices assembled below are provided as a guide for hose selection, installation and maintenance. Careful consideration for applying these practices is recommended.

Pressure

Determine the maximum operating system pressure and select a hose that will have a maximum working pressure equal to or in excess of the operation system's maximum pressure. It is very important to take into account surge pressures that may be higher than normal operating pressures.

Temperature

Determine the maximum and minimum operating temperatures and select a hose that is designed for use within this temperature range. Consider transient thermal conditions resulting from startup, heat build up from idling, etc. Special protection from hot equipment may be required.

Chemical and Environmental Resistance

Determine the type and concentration of the fluids and chemicals that will come in contact with the hose core tube I.D. and hose cover. Refer to the hose and tubing sections with product descriptions to identify the types of polymers used to form the core tube and cover. With this information, locate the compatibility rating of the combination of chemicals and/or fluids with the polymer type described in the Chemical Resistance data on pages I12-13. Contact Eaton technical support to request data for chemicals and conditions not listed.

Size

Select the proper I.D. based on system requirements such as fluid flow rate or velocity. The hose selection nomograph on page I4 can help determine the hose I.D.

Electrical Conductivity

Each hose application should be evaluated for the importance of selecting a hose designed to prevent flow of electrical current (e.g. aerial hydraulics) or a hose designed to sufficiently conduct static electricity to safe ground connections. The conducting hose design requires special conducting fittings which should be selected along with the hose.

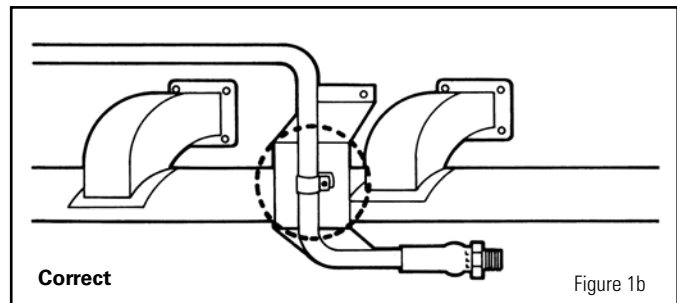
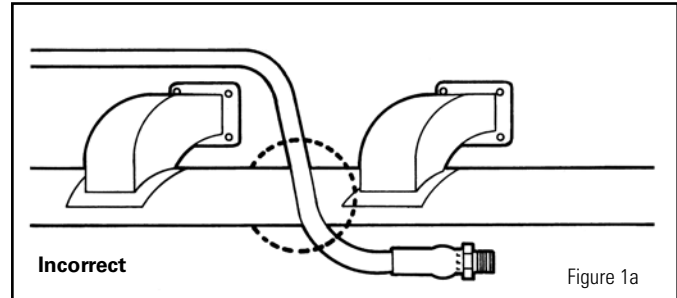

Component Inspection

Prior to installation, inspect hose for I.D. obstruction or damage such as blisters, looseness or cracks in the hose cover and evidence of having been kinked. Check fittings for thread damage or bent fitting components.

Routing

Many problems can be avoided by installing hose and hose assemblies away from hot equipment such as exhaust manifolds. Insulating heat shields may be necessary in some cases (Figure 1).

Selection, Installation and Maintenance of Synflex Hose and Assemblies

Minimum Bend Radius

Tight bends (Figure 2) that exceed the hose minimum bend radius should be avoided. Spring guards or stress relief sleeves may be required to protect against exceeding prescribed minimum bend radii.

Torsional Flexing

When equipment parts exhibit relative motion, hose connections should be located so hoses bend instead of twist.

Fitting Connections

Follow the fitting installation instructions provided in this catalog or enclosed with assembly equipment and described in product standards. Attach only the fittings specified for each hose design and do not mix components that are produced by different manufacturers. Proper fitting end selection is very important to eliminate twists and kinks in installed assemblies when connecting fittings to port connections. Swivel fittings are designed to allow for the hex rotation during tightening and bent tube or elbow fittings can eliminate kinks (Figure 3).

Torque Wrench Application

Use torque values where specified when tightening fitting connections to prevent leakage and damage.

Final Check Out

After components are assembled, purge entrapped air and pressurize system to maximum operating pressure. Inspect for leaks and proper function. Perform electrical conductivity tests on designs serving as static electricity discharge paths.

It is important that designers and users consider hose and hose assemblies as having a finite life. Therefore maintenance and replacement is usually necessary at specific intervals.

Maintenance Interval

Frequency of maintenance inspection should be determined by the system designer as well as user feedback based on the severity of the application, including service life data and risk potential.

Maintenance Program

Recommended maintenance should include the following steps as minimum practice:

Leakage

Turn off equipment and bleed down pressures prior to inspection to minimize risk to personnel. Inspect the full length of the hose and fitting connections for leaks.

Damage

Inspect hose for cuts, abrasion, cracks, blisters, kinked or crushed areas, heat degradation or cover looseness at the port or hose connection. Inspect hose guards for damage.

Electrical Continuity

In applications requiring the hose assembly to conduct static electricity to a ground connection, test hose assemblies using a megohmmeter in accordance with recommended procedures described on the permanently attached tag.

Replacement

Hose and/or assembly replacement should be considered at specific intervals under normal conditions. If leakage, loss of conductivity (when required), fitting separation and/or signs of damage are detected, the hose assembly should be replaced immediately.

Hose Routing

Under pressure, a hose may change in length. Always provide some slack in the hose to allow for this shortening or elongation. However, excessive slack in hose lines may cause poor appearance (Figure 4).

Figure 2

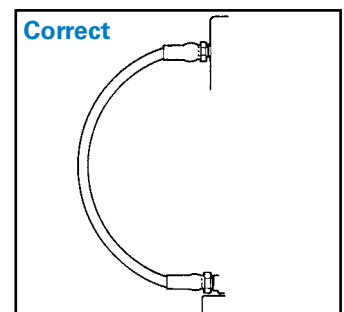
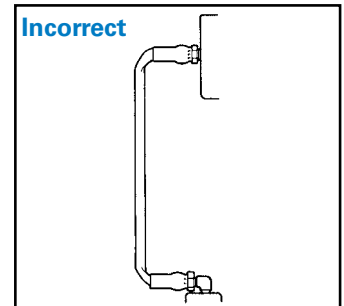

Figure 3

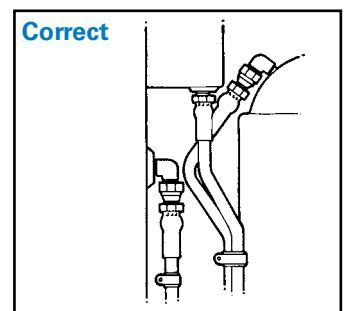
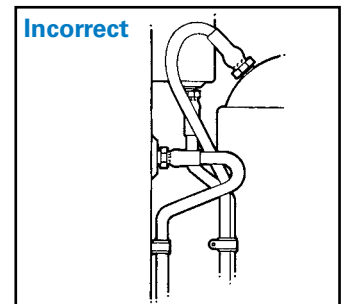
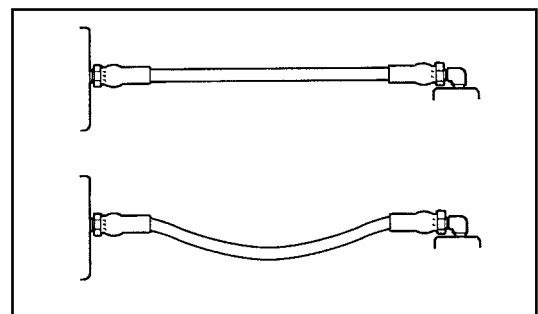

Figure 4

Incorrect



Correct

How to Assemble Permanent Hose Fittings

Synflex Mark IX Swaging Machine

Permanent Fitting Chart Insertion Depth Table

Hose I.D. (in)	Fitting Series Insertion Depth (in)	
	903, 90H, 90L, 90A, 90N	906
1/8	9/16	-
3/16	25/32	-
1/4	1-1/16	7/8
5/16	1-1/8	-
3/8	1-1/4	1-1/4
1/2	1-1/2	1-1/2
5/8	1-9/16	-
3/4	1-11/16	-
1	2-1/16	-



1. Cut hose squarely with hand-held hose cutter 4523-04006 or bench-mounted hose cutter 4523-04007.



2. Mark hose for proper insertion depth into fitting. Use insertion depth chart or use insertion depth marker 45J0-04603.



3. Oil inside hose diameter with SAE 20 oil.

Consult Eaton's Technical Support for oxygen system special assembly recommendations.



4. Insert hose into fitting to depth mark. (Use vise block 4504-00000 or 4504-01000 and rubber mallet to ease assembly.)



5. Insert the specified die and pusher into the swaging machine.



6. Lubricate die swaging surface with SAE 90 gear oil. For stainless steel fittings use swage lubricant 4545-01001.



7. Insert hose end into the pusher.



8. Pull control lever and guide fitting into the die until the pusher bottom is against the top of the die surface.



9. Push control lever to retract pusher and open die halves. Remove swaged hose assembly.

How to Assemble Permanent Hose Fittings

Synflex SST Swaging Tool

Permanent Fitting Chart Insertion Depth Table

Hose I.D. (in)	Fitting Series Insertion Depth (in)	
	903, 90A, 90H, 90L, 90N	906
1/8	9/16	-
3/16	25/32	-
1/4	1-1/16	7/8
5/16	1-1/8	-
3/8	1-1/4	1-1/4
1/2	1-1/2	-
5/8	1-9/16	-
3/4	1-11/16	-
1	2-1/16	-



1. Cut hose squarely with hand-held hose cutter 4523-04006 or bench-mounted hose cutter 4523-04007.



2. Mark hose for proper insertion depth into fitting. Use insertion depth chart or use insertion depth marker 45J0-04603.



3. Lubricate inside hose diameter with SAE 20 oil.

Consult Eaton's Technical Support for oxygen system special assembly recommendations.



4. Insert hose into fitting to depth mark. (Use vise block 4504-00000 or 4504-01000 and rubber mallet to ease assembly.)



5. Insert the specified pusher with the pusher retainer in the raised position. Fingertighten retaining screw to hold pusher firmly in place. Pusher must be allowed to rotate freely.



6. Place one die half into the base plate. **Lightly oil the inner surface of both die halves with SAE 90 gear oil. For stainless steel fittings use swage lubricant 4545-01001.**



7. Insert the assembled hose and fitting through the base plate and firmly into the pusher cavity. Place the other die half in base and lock into place by swinging clamps down firmly against top of dies. Rotate ball screw until fitting reaches the die.



8. With handle provided or 1-1/8 socket and ratchet, rotate screw clockwise until pusher bottom contacts top of die. Maintain pressure on ball screw and release die clamps. Slowly release pressure and rotate ball screw counterclockwise until it is clear of the die. Remove swaged assembly.

GENERAL
INFORMATION

HYDRAULIC
HOSE

AIR & WATER HOSE
& TUBING

TRUCK
HOSE

AEROQUIP/POLYON
FITTINGS

AEROQUIP/TTC
FITTINGS

SYNFLEX
FITTINGS

WEATHERHEAD
(U & Z SERIES)
FITTINGS

ASSEMBLY
EQUIPMENT &
INFORMATION

TECHNICAL
DATA

How to Assemble Reusable Hose Fittings

Synflex 3R80, 3E80, 37AL

* Consult Eaton Training for oxygen system assembly recommendations.

Reusable Fitting Chart Insertion Depth Table

Hose I.D. (in)	Fitting Series Insertion Depth (in)	
	902, 904, 908	
1/8	21/32	-
3/16	27/32	27/32
1/4	1	7/8
5/16	1-3/32	1-1/8
3/8	1-3/16	1-1/4
1/2	1-5/16	1-1/2
3/4	1-1/4	1-11/16
1	1-11/16	-



1. Cut hose squarely with hand-held hose cutter 4523-04006 or bench-mounted hose Cutter 4523-04007.



2. Use the table (to the right) to establish the length of hose that is inserted into the fitting socket. Use a rule for measurement and mark the hose with a colored pencil.

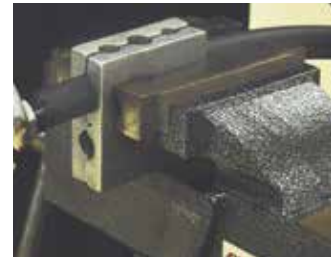

3. Insert hose into vise blocks (4504-0000 or 4504-01000) and tighten to hold hose firmly in place.



4. Lightly lubricate the outer surface of the hose to make it easier to push the fitting over the hose. For mild steel fittings and standard hose, use SAE 20 motor oil. For stainless steel fittings use swage lubricant 4545-01001*.



5. Push fitting socket over the lubricated hose and screw socket on by hand counterclockwise until the socket end is even with the depth mark. The end of the hose should be 3/32 inch to 1/16 inch from the inner shoulder of the fitting socket. It should NOT be bottomed against the shoulder. Do not over-tighten.



6. Remove hose and fitting assembly from vise block.
7. Place fitting socket in the vise and lubricate the mating fitting threads.



8. Screw the fitting insert clockwise into the socket with a wrench until the bottom of the inserted hex contacts the socket shoulder. Do not over-tighten.

How to Separate Twin Line & Multi-Line Hose

Synflex De-Twiner Die Reference Chart (4574-03000-xxx)

Hose Product	Die* No.	Hose Product	Die* No.	Hose Product	Die* No.
3R30-03	027	37AL-08	013	3VEO-03	005
3R30-04	003	30CT-04	003	3VEO-04	016
3R30-06	010	30CT-05	022	3VEO-06	017
3R30-08	013	30CT-06	011		
		30CT-08	014	3840-03	018
3130-02	001			3840-04	019
3130-03	002	3360-03	002	3840-06	020
3130-04	004	3360-04	004	3840-08	021
3130-05	008	3360-05	023		
3130-06	011	3360-06	024	35NG-03	004
3130-08	013	3360-08	025	35NG-04	026
				35NG-06	012
3160-03	002	3R80-04	009	35NG-08	015
3160-04	004	3R80-06	012		
3160-05	008	3R80-08	015	3V20-04	016
3160-06	011	3E80-04	009	3V20-06	017
3160-08	013	3E80-06	012		
		3E80-08	015	3251-08	006
37AL-03	002				
37AL-04	003	3V10-03	005	31DW-04	005
37AL-05	007	3V10-04	016		
37AL-06	010	3V10-06	017		

*Die number stamped on end.

Instructions for using the Twin-Line Hose Separation Tool

CAUTION: Tool Contains a Sharp Blade. Do Not Put Your Hands or Objects Inside the Tool.



- The De-Twiner tool 4574-01000 is designed to split twinned hose without any damage to the hose. Selecting the proper die is critical to operating this tool safely. The proper die can be selected from the provided chart. Customer service can assist in proper die selection. The hose should fit snugly in the die without extra play.
- To insert the die into the tool, first remove the retainer pin. This pin should also fit snugly to prevent the die from moving. **DO NOT REACH INTO THE TOOL OR PUSH ANYTHING THROUGH THE TOOL TO REMOVE THE DIE!** The die extends out one side of the tool to allow ease of removal. Set the tool on its side with the long end of the die pointing up. Remove the die. Insert the new die from the same side and reset the pin.
- Insert the assembled tool with die into a proper holding fixture (vise or other) and set stop at appropriate distance. The tool is cutting 2" before the exit end of the tool.
- Apply a water soluble lubricant to the end of the first piece of product to be cut and slide it through the tool to the appropriate stop. Apply a few drops of lubricant to the end of each hose to be cut just before cutting. This will ease the cutting force and prolong blade life.

Blade Replacement



- Replacement blades are available from Eaton performance plastics.
- Use proper protective gear (cut resistant gloves) when replacing the blade. This blade is very sharp.
- Remove blade retainer nut and slide out blade retainer bolt. Tip tool over and the blade should fall out from the top. **DO NOT TRY TO REMOVE IT FROM THE SLOT, THE MATERIAL SLIDES THROUGH.**
- Insert new blade, bolt and nut. Tighten the locking nut only to the point that the bolt rotates as the product is cut. If it is too tight the blade and bolt will wear out prematurely.
- The blade will last for thousands of cuts if properly installed and the operating procedures are followed correctly.

How to Separate Twin Line & Multi-Line Hose

GENERAL INFORMATION

HYDRAULIC HOSE

AIR & WATER HOSE & TUBING

TRUCK HOSE

AEROQUIP/POLYON FITTINGS

AEROQUIP/TTC FITTINGS

SYNFLEX FITTINGS

WEATHERHEAD (U & Z SERIES) FITTINGS

ASSEMBLY EQUIPMENT & INFORMATION

TECHNICAL DATA

Instructions for using the Twin-Line Hose Separation Tool



1. Remove the hose separation knife (4573-00000) from the handle and place in a vise at a 45° angle to the top of the vise. Fasten securely in the vise jaws.



2. Measure and mark the distance to be separated.



3. Lightly lubricate the hoses on both sides at the connecting web with a soap solution or lubricating oil. This step reduces friction between the knife blade and hose cover surfaces, plus keeps the knife centered during the cutting step.



4. Push the hose into the "V" notch on the knife blade using a rocking motion to start the hoses into the blade.

How to Separate Twin Line & Multi-Line Hose

(continued)



5. Hold the hoses together and aligned with the blade while first pushing then pulling them to the mark, taking care not to cut the hose covers.



6. Wipe lubricant from the hose.



7. Examine the hose cover material where the hoses were attached to ensure they have not been cut, or the reinforcement fiber exposed. If the hose covers shows signs of damage, the hose assembly should not be placed in service. If no damage is apparent, proceed with normal hose assembly.

GENERAL
INFORMATION

HYDRAULIC
HOSE

AIR & WATER HOSE
& TUBING

TRUCK
HOSE

AEROQUIP/POLYON
FITTINGS

AEROQUIP/TTC
FITTINGS

SYNFLEX
FITTINGS

WEATHERHEAD
(U & Z SERIES)
FITTINGS

ASSEMBLY
EQUIPMENT &
INFORMATION

TECHNICAL
DATA