

Inline Swivels

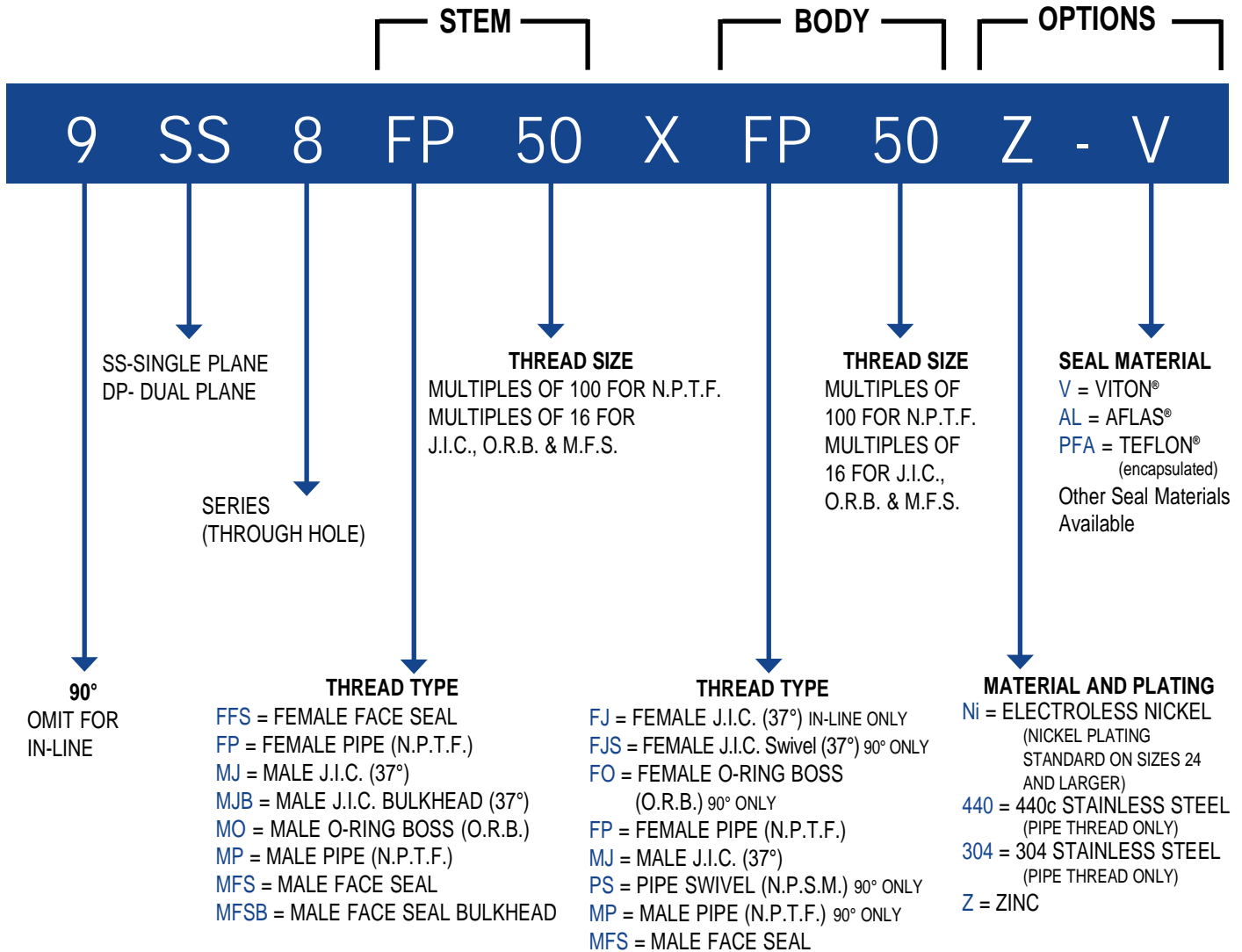

Switch Your Swivel![®]

HOW TO ORDER



REBUILDING KITS ARE AVAILABLE FOR ALL SWIVELS.

WHEN ORDERING PLEASE SPECIFY PRESSURE, TYPE OF MEDIA OR OXYGEN USE.

SUPER SWIVELS® ARE NOT RECOMMENDED FOR BREATHING AIR OR STEAM.

ALL SWIVELS HAVE 4 TO 1 PROOF PRESSURE, EXCEPT 10,000 P.S.I. 3 TO 1 PROOF PRESSURE

SUPER SWIVELS® MAY ALSO BE ORDERED BY ITEM NUMBER.

ANY SERIES STEM WILL FIT WITH THE SAME SERIES BODY. THEREFORE THERE ARE MANY COMBINATIONS THAT DO NOT APPEAR IN THIS CATALOG.

Options

Base Material and Plating

Super Swivels are manufactured from Carbon Steel or 304 and 440c Stainless Steel.

Carbon Steel Zinc (Z) Plating is recommended for non-corrosive applications, i.e. hydraulic, pneumatic, etc.

Carbon Steel Nickel (NI) Plating is recommended for mildly corrosive environments, i.e. water, mild chemicals, solvents, etc.

304 Stainless Steel (304) is recommended for low pressure corrosive environments.

440c Stainless Steel (440) is a martensitic, high carbon, magnetic stainless steel, heat-treated to maintain a high-pressure rating. Not as corrosion resistant as 300 Series Stainless Steel.

Seal Material

(V) Viton® (Fluorocarbon) – For most petroleum based applications. (-15°F to 250°F)

(AL) Aflas® (Tetrafluoroethylene-propylene copolymer) – Better resistance to many individual chemicals. For service in high temperature environments. (Low temperature limitations.) (+32°F to 400°F)

(PFA) PFA Teflon® – High resistance to many individual chemicals where Teflon seals are required. (1,500 max psi) (-15°F to 400°F)

Other seals available upon request include:

Buna, EPR, Neoprene and Kalrez®.

Please specify oxygen use when ordering. Super Swivels are not recommended for breathing air or steam.

• Viton and Kalrez are registered trademarks of DuPont Dow® Elastomers. • Teflon, Freon, and Hytrel are registered trademarks of the DuPont® Company.
• Aflas is a registered trademark of Asahi® Glass Co LTD. • Skydrol and Pydraul are registered trademarks of Monsanto® Chemical Co. All other ® and ™s are the property of their respective owners.

Seal Compatibility Chart

| FLUIDS | VITON® (HYTREL® back-up) 25 in/Hg-5000 P.S.I. MAX* -15°F TO 250°F | AFLAS® (TEFLON® back-up) 25 in/Hg-5000 P.S.I. MAX* +32°F TO 400°F | PFA TEFLON(TEFLONback-up) 25 in/Hg-1500 MAX -15°F TO 400°F |
|-------------------------------|---|---|--|
| automatic transmission fluids | A | A | A |
| acetone | C | C | C |
| air | A | A | A |
| asphalt | B | A | B |
| benzene | A | B | B |
| brake fluid (glycol) | C | A | B |
| brake fluid (mineral) | C | A | B |
| brake fluid (silicone) | C | A | B |
| carbon tetrachloride | A | C | A |
| engine oil (sf, sf cd) | A | A | A |
| ethylene glycol | A | A | A |
| FREON® | C | C | C |
| hydraulic fluids (petroleum) | A | A | A |
| hydrochloric acid | B | A | A |
| methyl ethyl ketone | C | C | C |
| naphtha | A | A | A |
| oxygen (gaseous) | A | A | A |
| power steering fluid | C | A | A |
| salt water | B | A | A |
| SKYDROL 500 B4® | C | B | C |
| soap solutions | C | A | A |
| sulfuric acid | A | A | A |
| toluene | A | C | B |
| trichlorethylene | A | C | A |
| urethane | C | A | C |
| water | C | A | A |

A=Satisfactory
B=Fair
C=Unsatisfactory

*2500 P.S.I. MAX PNEUMATIC

This chart is only a guide, several factors should be considered when selecting a sealing compound,

Note 1. Please specify oxygen use when ordering. Super Swivels® are not recommended for breathing air.

Not recommended for steam.

Super Swivels' Advantages

Simplified Connections:

- Super Swivels can connect directly to hose lines which would do away with adapters.
- Super Swivels reduce the complexity of hose lines for 90° connections.
- Less hose is required with Super Swivels live swivels reducing space needs.

Reduced Hose Twisting:

- Super Swivels live swivel action reduces risk of hose twisting and kinking even in 90° angle connections.

Less System Shock:

- The increased hose movement allowed by Super Swivels superior design reduces system rigidity and helps absorb some system impulses.

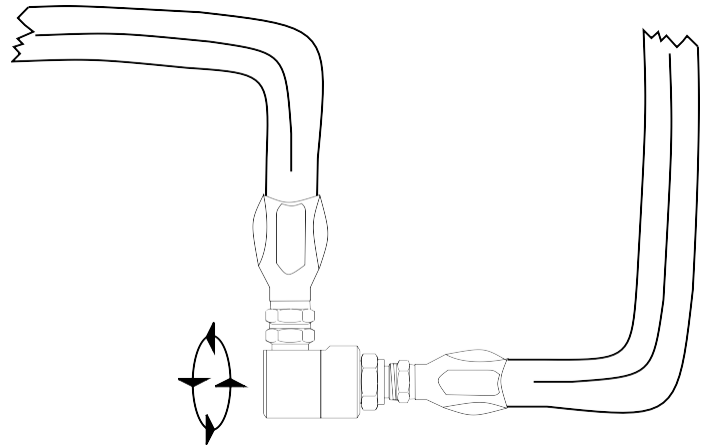

Reduce Maintenance and Downtime:

- Less hydraulic line congestion, hose kinking, shock damage and twisting means lower maintenance costs and less downtime.

Reduced Cost:

- Simplified hose configuration, less hose and adapters when combined with reduced repairs and downtime reduce the overall cost of hydraulics.

Cross Sectional Drawings

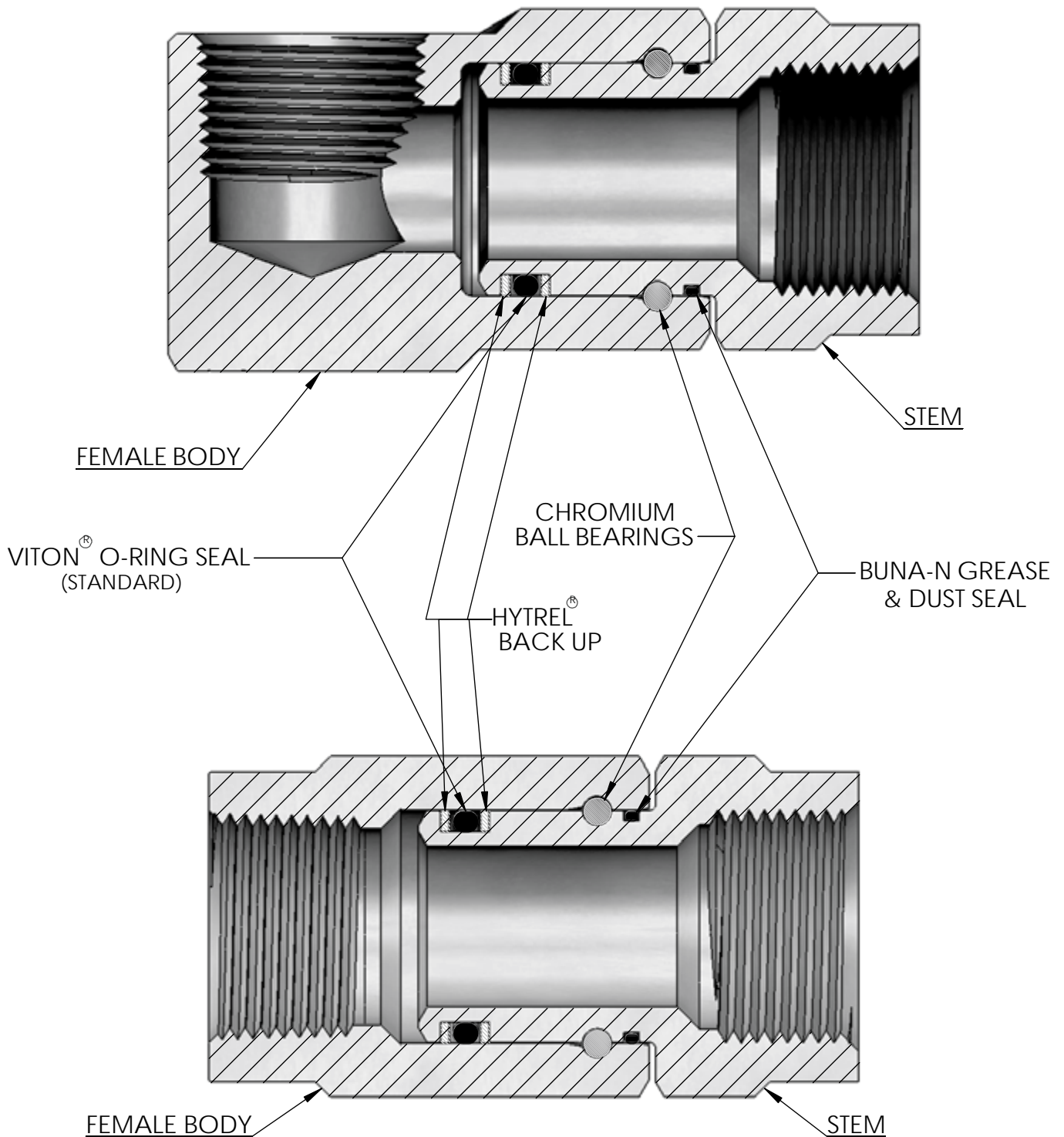

Zinc Plated for Hydraulic Oil Applications
Sizes 4 through 16

Cross Sectional Drawings

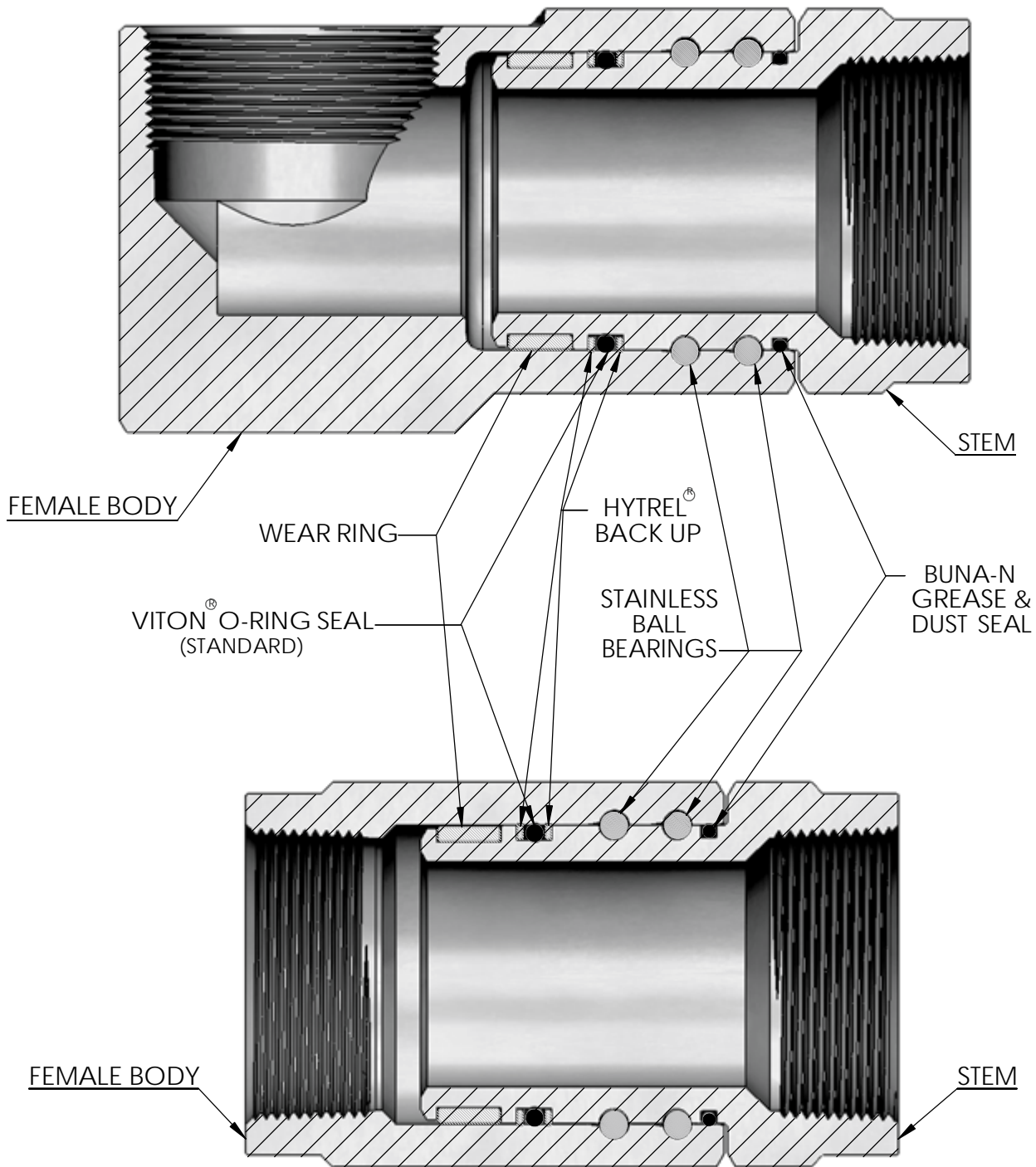

Nickel Plated for Hydraulic Oil Applications Sizes 20 through 40

(Size 20 No Wear Ring)

Nickel Plating Standard on Size 24 and Larger

Cross Sectional Drawings

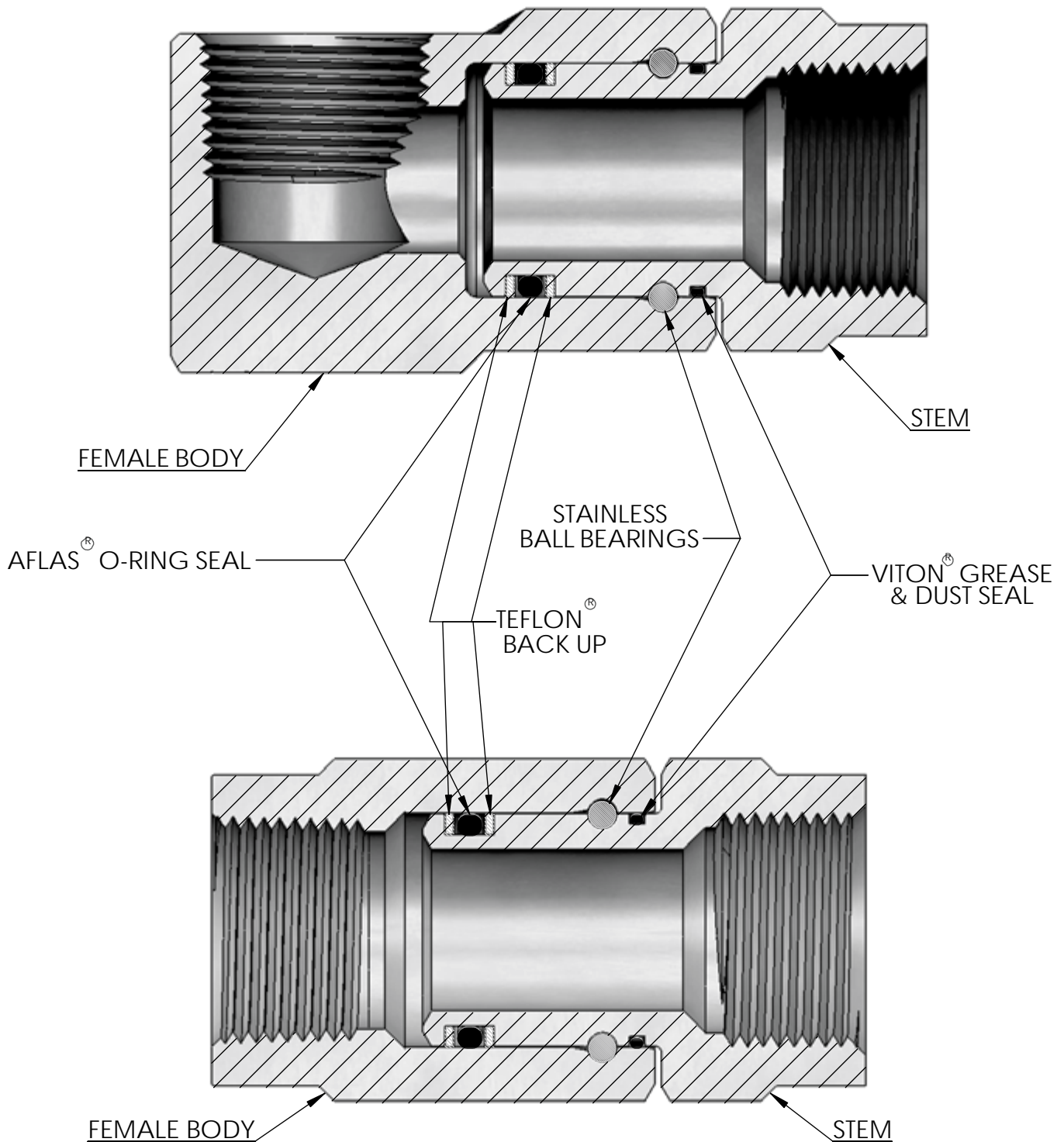

**Nickel Plated for Corrosive Media Applications
Sizes 4 through 16**

Cross Sectional Drawings

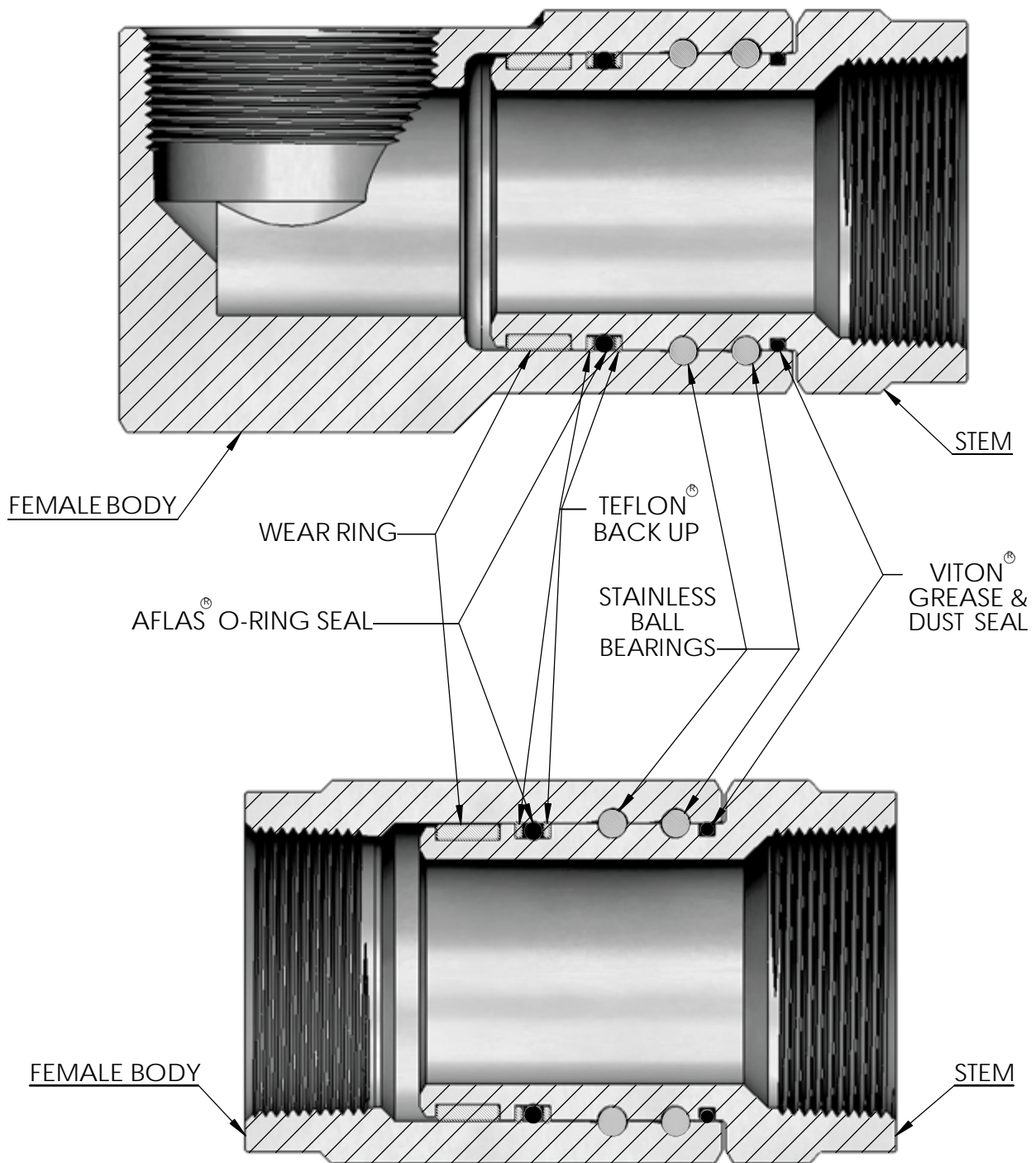

Nickel Plated for Corrosive Media Applications Sizes 20 through 40

(Size 20 No Wear Ring)

Nickel Plating Standard on Size 24 and Larger



Pressure Drop "SS" Inline #4 - #16

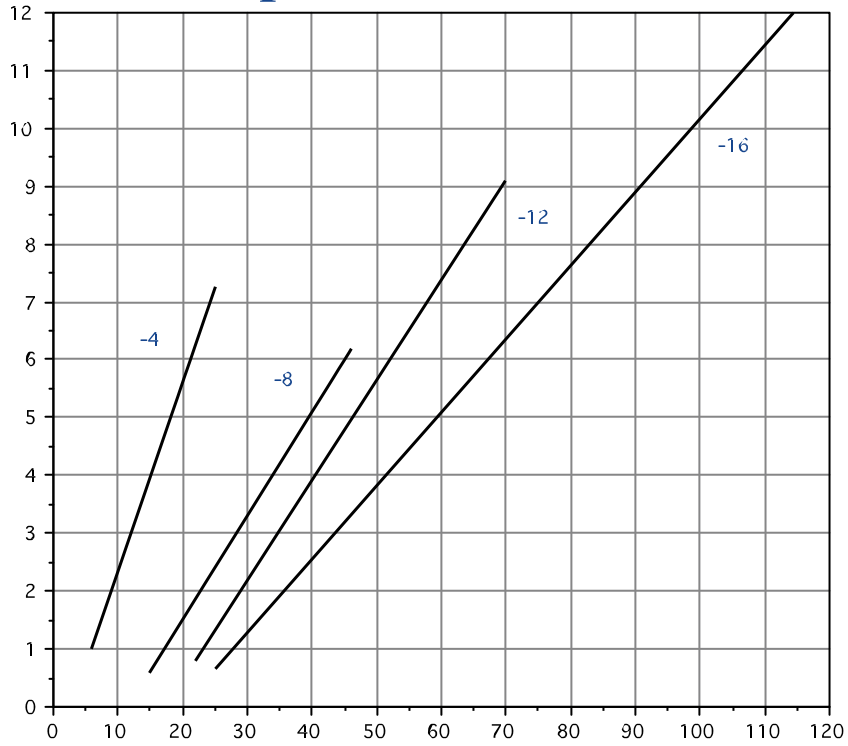

Pressure Drop "SS" Inline #20 - #40

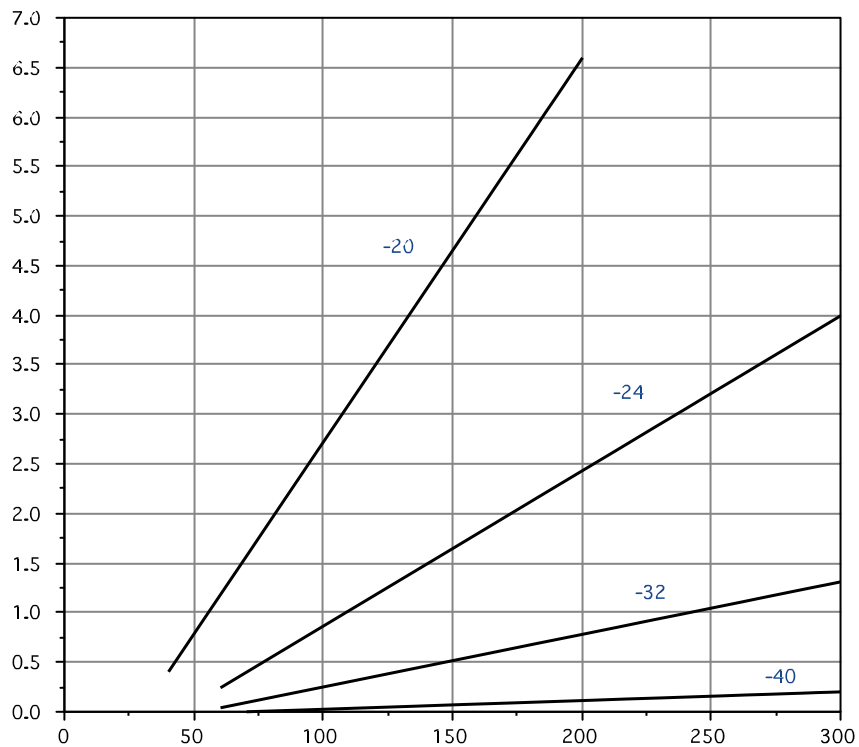



Pressure Drop "9SS" 90° #4 - #16

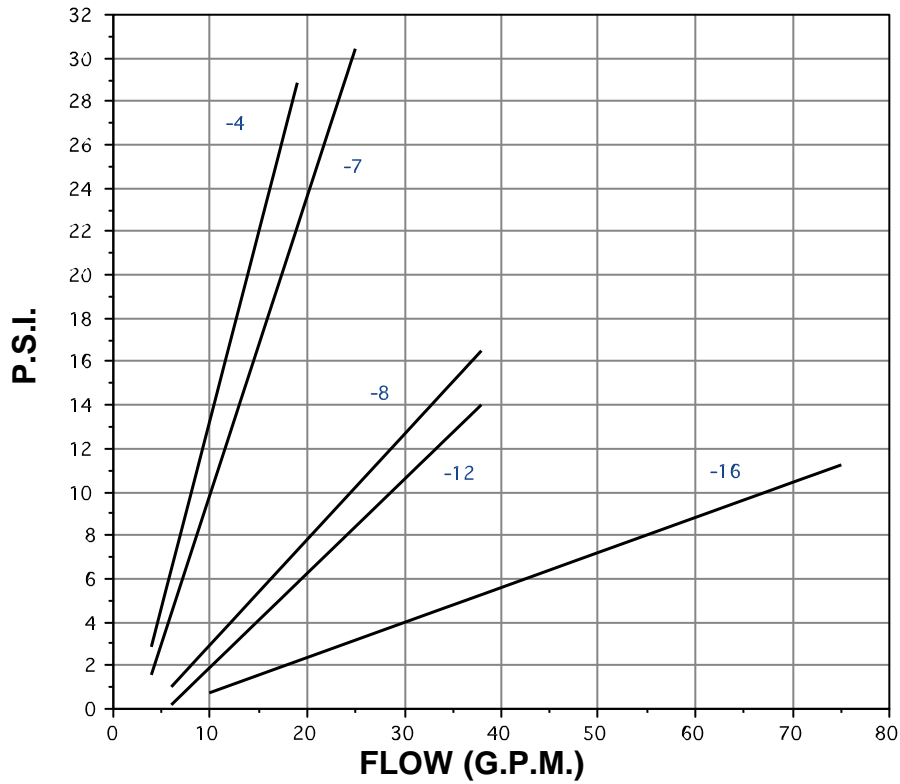

Pressure Drop "9SS" 90° #20 - #32

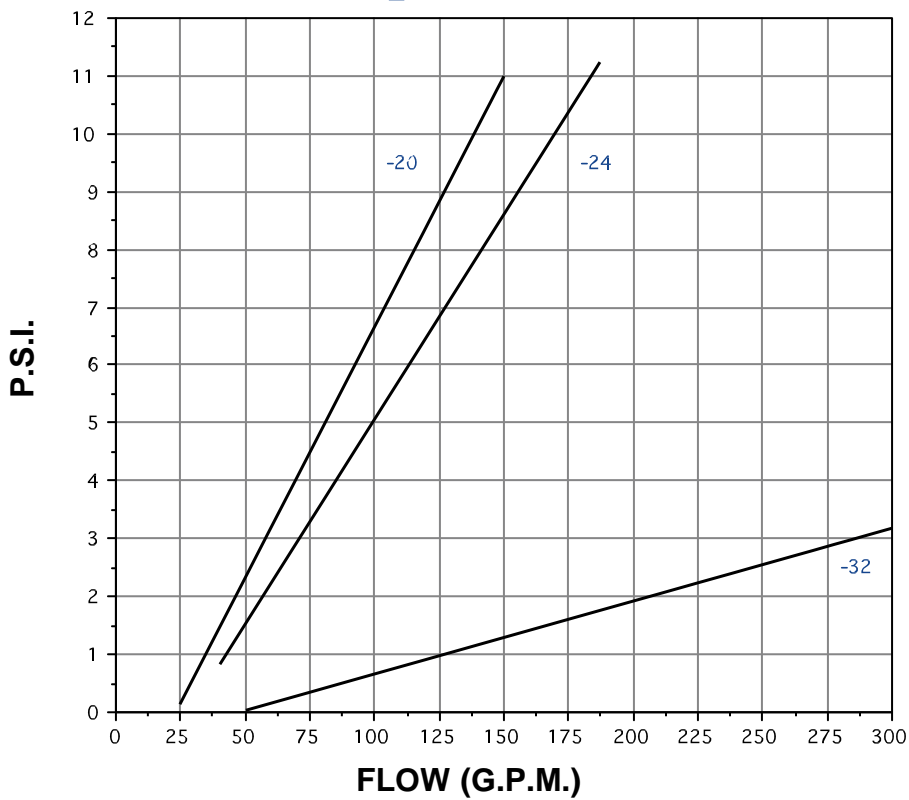



Rotating Torque vs. Pressure

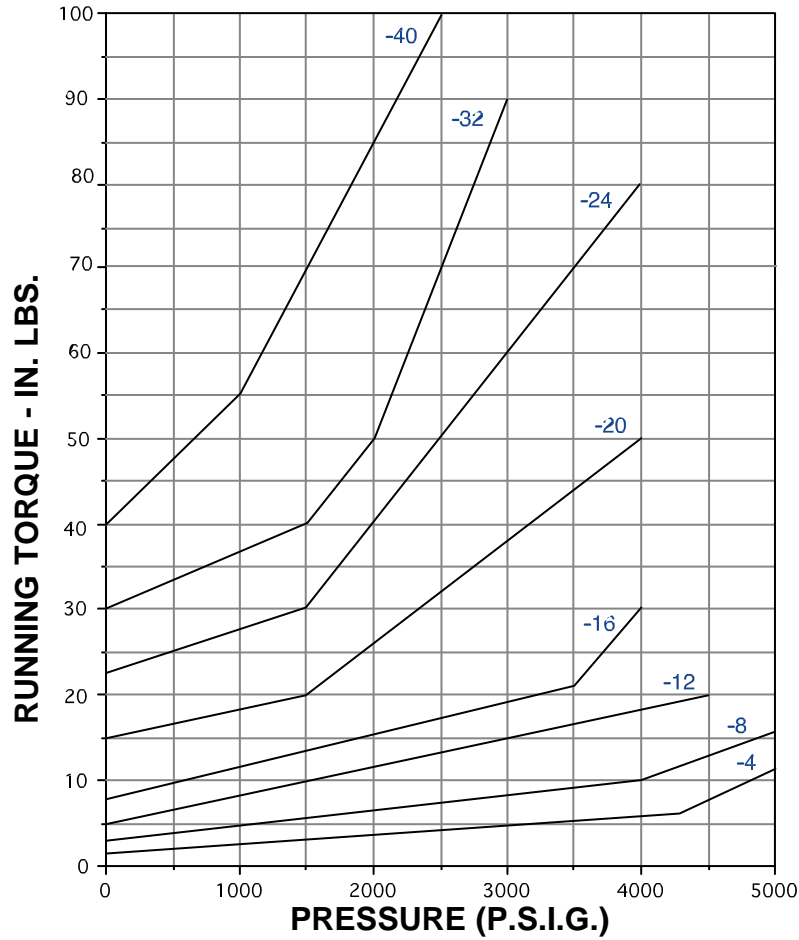

R.P.M. vs. P.S.I.

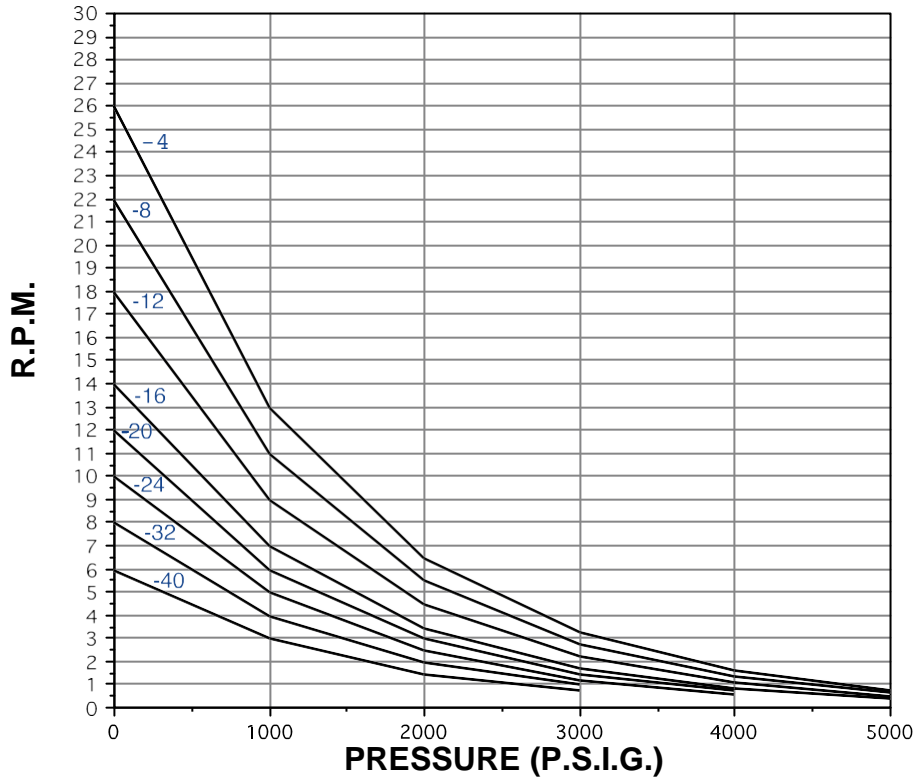

Note: For specific pressure see charts with diagrams.

Female Pipe (N.P.T.F.) X Female Pipe (N.P.T.F.)

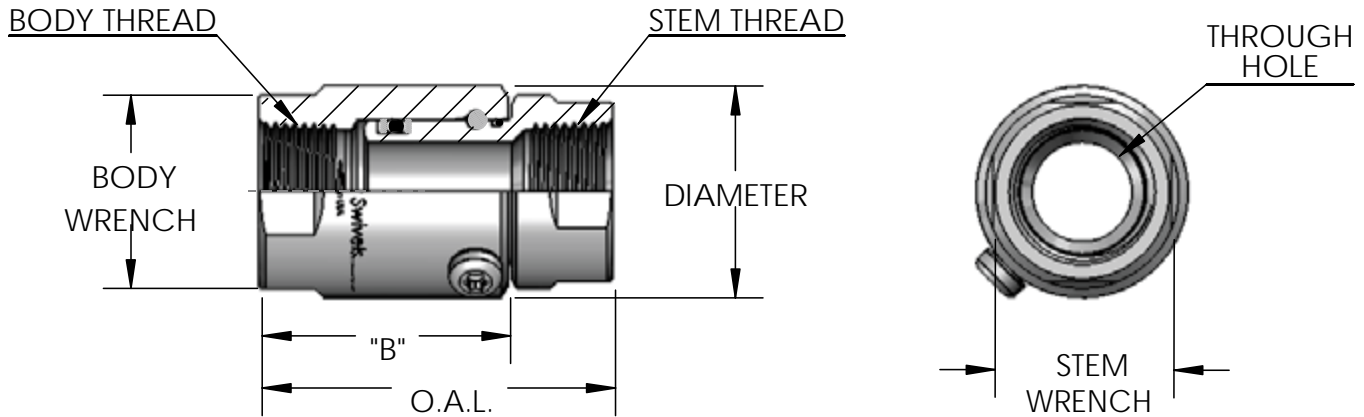

| PART NUMBER | O.A.L. | DIM. B | DIAMETER | STEM THREAD | BODY THREAD | BODY WRENCH | STEM WRENCH | MAX P.S.I.G. | THROUGH HOLE |
|------------------------|--------|--------|----------|-----------------------|-----------------------|-------------|-------------|--------------|--------------|
| SS 2 FP 12.5 X FP 12.5 | 1.785 | 1.225 | .734 | 1/8-27 N.P.T.F. | 1/8-27 N.P.T.F. | 0.625 | 0.625 | 5000 | 0.157 |
| SS 4 FP 25 X FP 25 | 2.320 | 1.720 | .992 | 1/4-18 N.P.T.F. | 1/4-18 N.P.T.F. | 0.875 | 0.750 | 5000 | 0.250 |
| SS 8 FP 38 X FP 38 | 2.255 | 1.550 | 1.290 | 3/8-18 N.P.T.F. | 3/8-18 N.P.T.F. | 1.125 | 0.875 | 5000 | 0.530 |
| SS 8 FP 50 X FP 50 | 2.480 | 1.650 | 1.480 | 1/2-14 N.P.T.F. | 1/2-14 N.P.T.F. | 1.250 | 1.125 | 5000 | 0.530 |
| SS 12 FP 75 X FP 75 | 2.685 | 1.850 | 1.675 | 3/4-14 N.P.T.F. | 3/4-14 N.P.T.F. | 1.500 | 1.375 | 4500 | 0.689 |
| SS 16 FP 100 X FP 100 | 3.200 | 2.685 | 1.918 | 1-11 1/2 N.P.T.F. | 1-11 1/2 N.P.T.F. | 1.750 | 1.625 | 4000 | 0.906 |
| SS 20 FP 125 X FP 125 | 3.680 | 2.685 | 2.358 | 1 1/4-11 1/2 N.P.T.F. | 1 1/4-11 1/2 N.P.T.F. | 2.125 | 2.000 | 4000 | 1.181 |
| SS 24 FP 150 X FP 150 | 4.050 | 2.950 | 2.548 | 1 1/2-11 1/2 N.P.T.F. | 1 1/2-11 1/2 N.P.T.F. | 2.375 | 2.375 | 4000 | 1.312 |
| SS 32 FP 200 X FP 200 | 4.520 | 3.450 | 3.052 | 2-11 1/2 N.P.T.F. | 2-11 1/2 N.P.T.F. | 2.875 | 2.875 | 3000 | 1.781 |
| SS 40 FP 250 X FP 250 | 5.165 | 3.785 | 3.572 | 2 1/2-8 N.P.T.F. | 2 1/2-8 N.P.T.F. | 3.375 | 3.375 | 2500 | 2.125 |

Male Pipe (N.P.T.F.) X Female Pipe (N.P.T.F.)

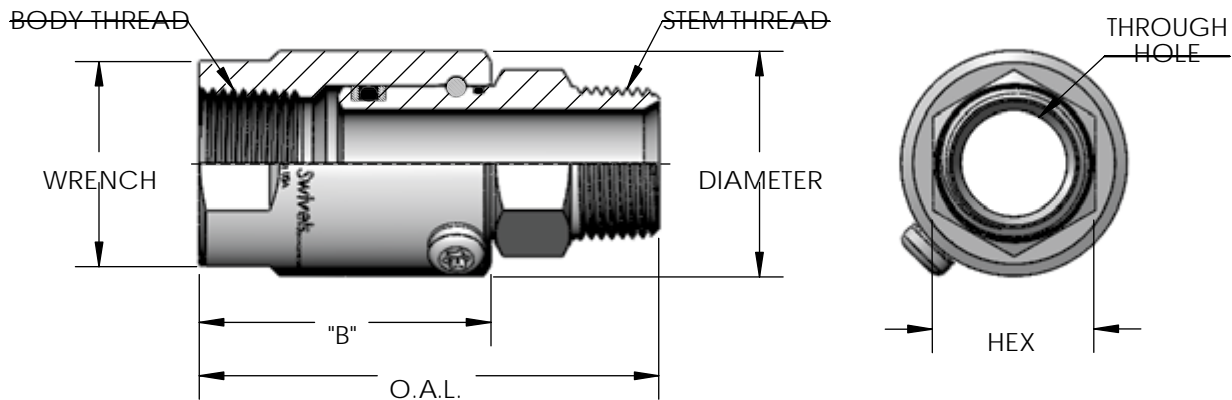

| PART NUMBER | O.A.L. | DIM. B | STEM THREAD | BODY THREAD | HEX | DIAMETER | WRENCH | MAX P.S.I.G. | THROUGH HOLE |
|------------------------|--------|--------|-----------------------|-----------------------|-------|----------|--------|--------------|--------------|
| SS 2 MP 12.5 X FP 12.5 | 1.855 | 1.225 | 1/8-27 N.P.T.F. | 1/8-27 N.P.T.F. | 0.437 | 0.734 | 0.625 | 5000 | 0.157 |
| SS 4 MP 25 X FP 25 | 2.450 | 1.720 | 1/4-18 N.P.T.F. | 1/4-18 N.P.T.F. | 0.625 | 0.992 | 0.875 | 5000 | 0.250 |
| SS 8 MP 38 X FP 38 | 2.680 | 1.570 | 3/8-18 N.P.T.F. | 3/8-18 N.P.T.F. | 1.000 | 1.292 | 1.125 | 5000 | 0.406 |
| SS 8 MP 50 X FP 50 | 2.840 | 1.650 | 1/2-14 N.P.T.F. | 1/2-14 N.P.T.F. | 1.000 | 1.480 | 1.250 | 5000 | 0.530 |
| SS 12 MP 75 X FP 75 | 3.085 | 1.850 | 3/4-14 N.P.T.F. | 3/4-14 N.P.T.F. | 1.125 | 1.675 | 1.500 | 4500 | 0.689 |
| SS 16 MP 100 X FP 100 | 3.675 | 2.480 | 1-11 1/2 N.P.T.F. | 1-11 1/2 N.P.T.F. | 1.375 | 1.917 | 1.750 | 4000 | 0.906 |
| SS 20 MP 125 X FP 125 | 4.190 | 2.685 | 1 1/4-11 1/2 N.P.T.F. | 1 1/4-11 1/2 N.P.T.F. | 1.750 | 2.357 | 2.125 | 4000 | 1.181 |
| SS 24 MP 150 X FP 150 | 4.625 | 2.950 | 1 1/2-11 1/2 N.P.T.F. | 1 1/2-11 1/2 N.P.T.F. | 2.000 | 2.550 | 2.375 | 4000 | 1.312 |
| SS 32 MP 200 X FP 200 | 5.050 | 3.450 | 2-11 1/2 N.P.T.F. | 2-11 1/2 N.P.T.F. | 2.500 | 3.055 | 2.875 | 3000 | 1.781 |

Male J.I.C. (37°) X Female Pipe (N.P.T.F.)

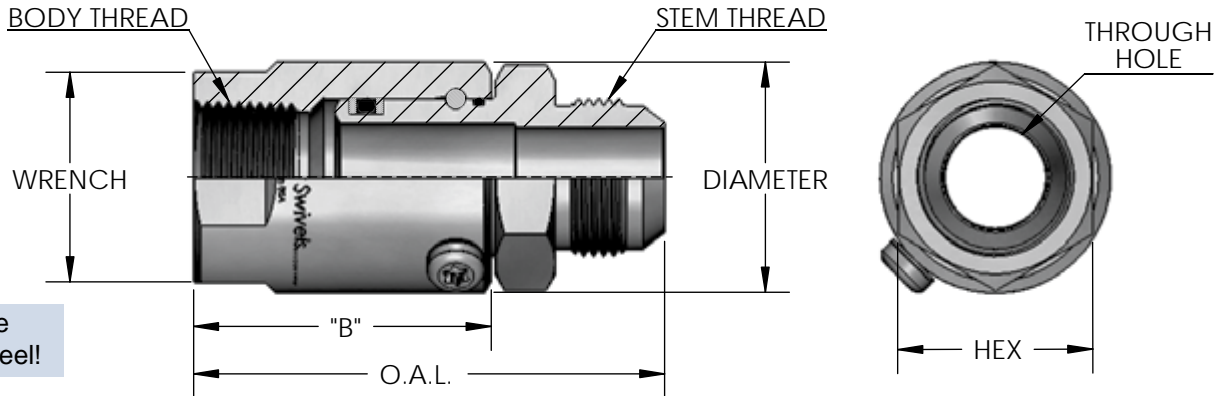

| PART NUMBER | O.A.L. | DIM. B | STEM THREAD | BODY THREAD | STEM HEX | DIAMETER | WRENCH | MAX P.S.I.G. | THROUGH HOLE |
|----------------------|--------|--------|----------------|-----------------------|----------|----------|--------|--------------|--------------|
| SS 4 MJ 6 X FP 25 | 2.670 | 1.720 | 9/16-18 U.N. | 1/4-18 N.P.T.F. | 0.750 | 0.992 | 0.875 | 5000 | 0.250 |
| SS 8 MJ 8 X FP 38 | 2.655 | 1.850 | 3/4-16 U.N. | 3/8-18 N.P.T.F. | 1.000 | 1.292 | 1.125 | 5000 | 0.406 |
| SS 8 MJ 8 X FP 50 | 2.740 | 1.650 | 3/4-16 U.N. | 1/2-14 N.P.T.F. | 1.000 | 1.480 | 1.250 | 5000 | 0.406 |
| SS 8 MJ 10 X FP 50 | 2.840 | 1.650 | 7/8-14 U.N. | 1/2-14 N.P.T.F. | 1.000 | 1.480 | 1.250 | 5000 | 0.484 |
| SS 12 MJ 12 X FP 75 | 3.210 | 1.850 | 1 1/16-12 U.N. | 3/4-14 N.P.T.F. | 1.375 | 1.675 | 1.500 | 4500 | 0.609 |
| SS 16 MJ 16 X FP 100 | 3.700 | 2.480 | 1 5/16-12 U.N. | 1-11 1/2 N.P.T.F. | 1.625 | 1.917 | 1.750 | 4000 | 0.844 |
| SS 20 MJ 20 X FP 125 | 4.230 | 2.685 | 1 5/8-12 U.N. | 1 1/4-11 1/2 N.P.T.F. | 1.750 | 2.357 | 2.125 | 4000 | 1.078 |
| SS 24 MJ 24 X FP 150 | 4.715 | 2.950 | 1 7/8-12 U.N. | 1 1/2-11 1/2 N.P.T.F. | 2.125 | 2.547 | 2.370 | 4000 | 1.312 |

Male J.I.C. (37°) X Female J.I.C. (37°)

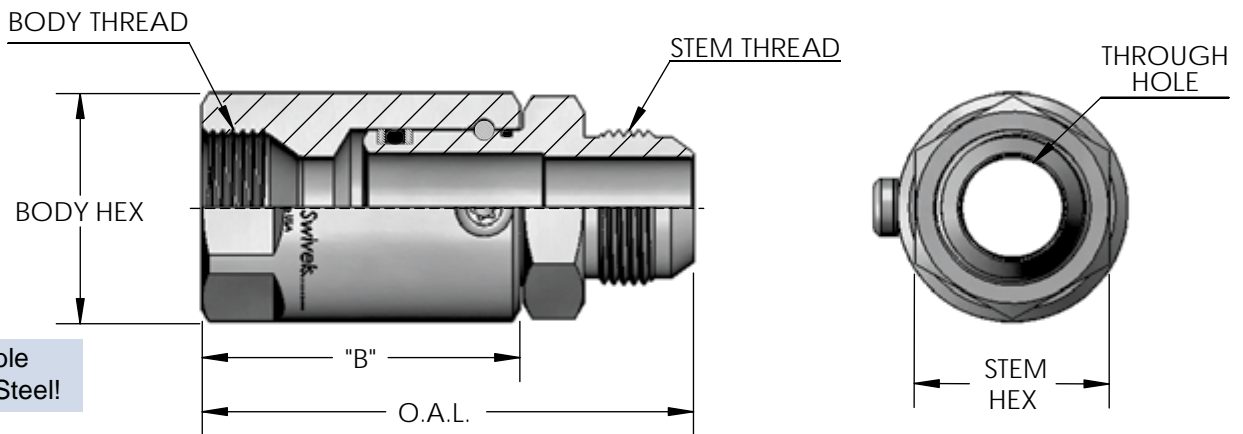

| PART NUMBER | O.A.L. | DIM. B | STEM THREAD | BODY THREAD | STEM HEX | BODY HEX/WRENCH | BODY DIA. | MAX P.S.I.G. | THROUGH HOLE |
|---------------------|--------|--------|----------------|----------------|----------|-----------------|-----------|--------------|--------------|
| SS 4 MJ 4 X FJ 4 | 2.578 | 1.648 | 7/16-20 U.N. | 7/16-20 U.N. | 0.750 | 1.000 | HEX | 5000 | 0.172 |
| SS 4 MJ 5 X FJ 5 | 2.578 | 1.648 | 1/2-20 U.N. | 1/2-20 U.N. | 0.750 | 1.000 | HEX | 5000 | 0.234 |
| SS 4 MJ 6 X FJ 6 | 2.770 | 1.820 | 9/16-18 U.N. | 9/16-18 U.N. | 0.750 | 1.000 | HEX | 5000 | 0.250 |
| SS 8 MJ 8 X FJ 8 | 3.035 | 1.950 | 3/4-16 U.N. | 3/4-16 U.N. | 1.000 | 1.375 | 1.480 | 5000 | 0.406 |
| SS 8 MJ 10 X FJ 10 | 3.235 | 2.050 | 7/8-14 U.N. | 7/8-14 U.N. | 1.000 | 1.375 | 1.480 | 5000 | 0.484 |
| SS 12 MJ 12 X FJ 12 | 3.505 | 2.145 | 1 1/16-12 U.N. | 1 1/16-12 U.N. | 1.375 | 1.625 | 1.675 | 4500 | 0.609 |
| SS 16 MJ 16 X FJ 16 | 4.091 | 2.646 | 1 5/16-12 U.N. | 1 5/16-12 U.N. | 1.625 | 1.750 | 1.917 | 4000 | 0.844 |
| SS 20 MJ 20 X FJ 20 | 4.395 | 2.850 | 1 5/8-12 U.N. | 1 5/8-12 U.N. | 1.750 | 2.125 | 2.357 | 4000 | 1.078 |
| SS 24 MJ 24 X FJ 24 | 5.175 | 3.410 | 1 7/8-12 U.N. | 1 7/8-12 U.N. | 2.125 | 2.375 | 2.550 | 4000 | 1.312 |

Male O-Ring (O.R.B.) X Female Pipe (N.P.T.F.)

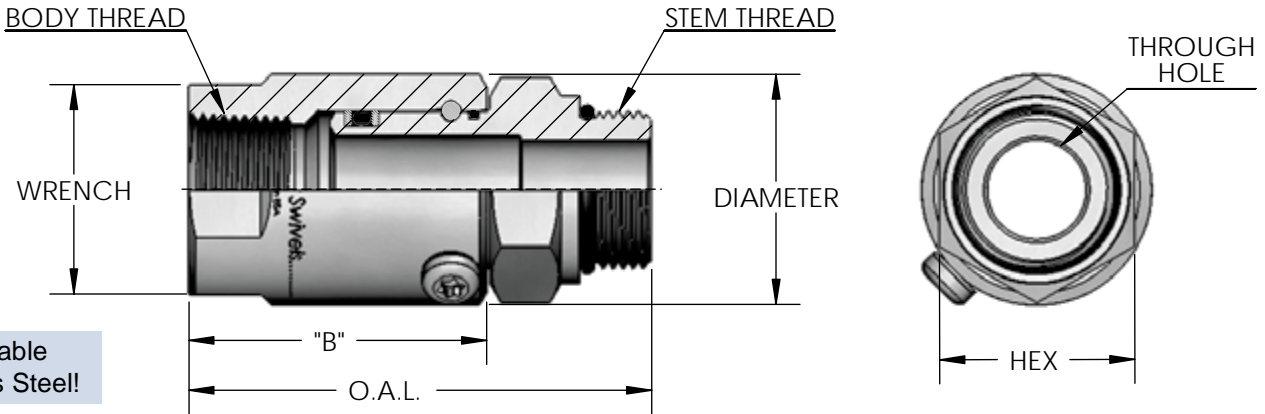

| PART NUMBER | O.A.L. | DIM. B | STEM THREAD | BODY THREAD | HEX | DIAMETER | WRENCH | MAX P.S.I.G. | THROUGH HOLE |
|----------------------|--------|--------|----------------|-----------------------|-------|----------|--------|--------------|--------------|
| SS 4 MO 6 X FP 25 | 2.540 | 1.720 | 9/16-18 U.N. | 1/4-18 N.P.T.F. | 0.750 | 0.992 | 0.875 | 5000 | 0.250 |
| SS 8 MO 8 X FP 38 | 2.510 | 1.550 | 3/4-16 U.N. | 3/8-18 N.P.T.F. | 1.000 | 1.292 | 1.125 | 5000 | 0.406 |
| SS 8 MO 8 X FP 50 | 2.590 | 1.650 | 3/4-16 U.N. | 1/2-14 N.P.T.F. | 1.000 | 1.480 | 1.250 | 5000 | 0.406 |
| SS 8 MO 10 X FP 50 | 2.710 | 1.650 | 7/8-14 U.N. | 1/2-14 N.P.T.F. | 1.000 | 1.480 | 1.250 | 5000 | 0.484 |
| SS 12 MO 12 X FP 75 | 3.074 | 1.850 | 1 1/16-12 U.N. | 3/4-14 N.P.T.F. | 1.375 | 1.675 | 1.500 | 4500 | 0.609 |
| SS 16 MO 16 X FP 100 | 3.625 | 2.250 | 1 5/16-12 U.N. | 1-11 1/2 N.P.T.F. | 1.625 | 1.917 | 1.750 | 4000 | 0.827 |
| SS 20 MO 20 X FP 125 | 4.150 | 2.685 | 1 5/8-12 U.N. | 1 1/4-11 1/2 N.P.T.F. | 1.875 | 2.357 | 2.125 | 4000 | 1.078 |
| SS 24 MO 24 X FP 150 | 4.550 | 2.950 | 1 7/8-12 U.N. | 1 1/2-11 1/2 N.P.T.F. | 2.125 | 2.547 | 2.375 | 4000 | 1.312 |

Male J.I.C. Bulkhead (37°) X Female J.I.C. (37°)

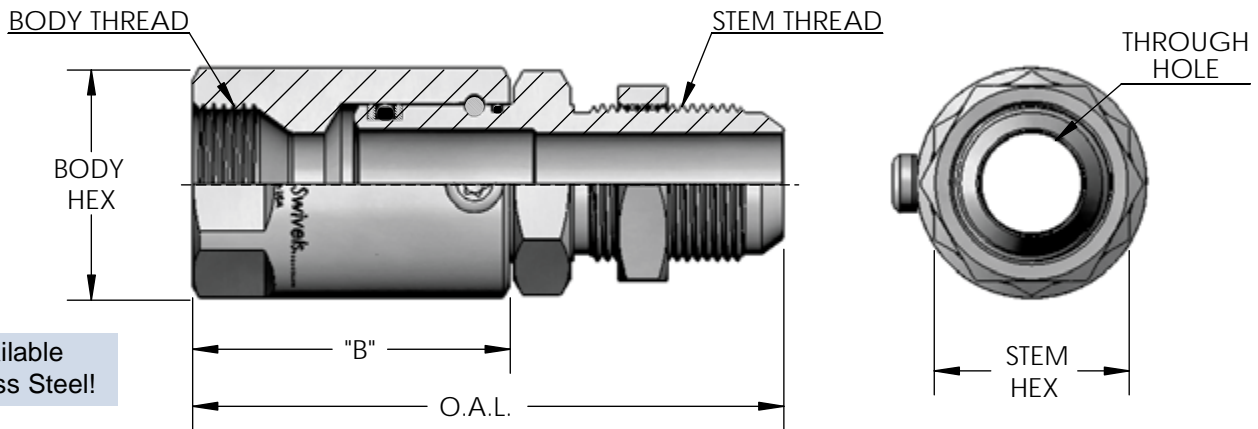

| PART NUMBER | O.A.L. | DIM. B | STEM THREAD | BODY THREAD | STEM HEX | BODY HEX/WRENCH | BODY DIA. | MAX P.S.I.G. | THROUGH HOLE |
|----------------------|--------|--------|----------------|----------------|----------|-----------------|-----------|--------------|--------------|
| SS 4 MJB 6 X FJ 6 | 3.410 | 1.820 | 9/16-18 U.N. | 9/16-18 U.N. | .812 | 1.000 | 1.100 | 5000 | 0.250 |
| SS 8 MJB 8 X FJ 8 | 3.770 | 1.950 | 3/4-16 U.N. | 3/4-16 U.N. | 1.000 | 1.375 | 1.480 | 5000 | 0.406 |
| SS 8 MJB 10 X FJ 10 | 4.090 | 2.050 | 7/8-14 U.N. | 7/8-14 U.N. | 1.125 | 1.375 | 1.480 | 5000 | 0.484 |
| SS 12 MJB 12 X FJ 12 | 4.425 | 2.145 | 1 1/16-12 U.N. | 1 1/16-12 U.N. | 1.375 | 1.625 | 1.675 | 4500 | 0.609 |
| SS 16 MJB 16 X FJ 16 | 4.926 | 2.646 | 1 5/16-12 U.N. | 1 5/16-12 U.N. | 1.625 | 1.750 | 1.917 | 4000 | 0.844 |
| SS 20 MJB 20 X FJ 20 | 5.290 | 2.850 | 1 5/8-12 U.N. | 1 5/8-12 U.N. | 1.875 | 2.125 | 2.357 | 4000 | 1.078 |

Male J.I.C. Bulkhead (37°) X Male J.I.C. (37°)

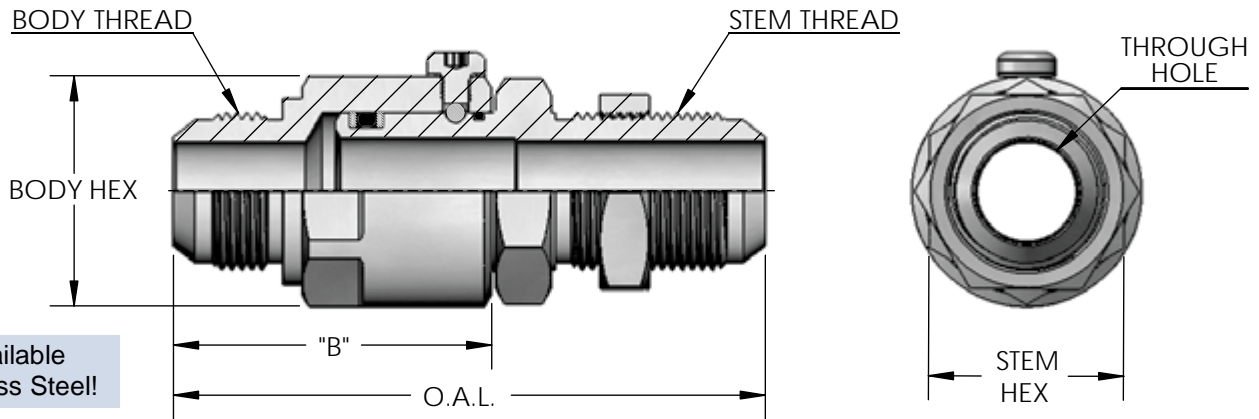

| PART NUMBER | O.A.L | DIM. B | STEM THREAD | BODY THREAD | STEM HEX | BODY HEX/WRENCH | BODY DIA. | MAX P.S.I.G. | THROUGH HOLE |
|----------------------|-------|--------|---|---|----------|-----------------|-----------|--------------|--------------|
| SS 4 MJB 6 X MJ 6 | 3.310 | 1.720 | 9/16-18 U.N. | 9/16-18 U.N. | .812 | 1.000 | 1.100 | 5000 | 0.250 |
| SS 8 MJB 8 X MJ 8 | 3.720 | 1.900 | 3/4-16 U.N. | 3/4-16 U.N. | 1.000 | 1.375 | 1.480 | 5000 | 0.406 |
| SS 8 MJB 10 X MJ 10 | 4.090 | 2.050 | 7/8-14 U.N. | 7/8-14 U.N. | 1.125 | 1.375 | 1.480 | 5000 | 0.484 |
| SS 12 MJB 12 X MJ 12 | 4.405 | 2.125 | 1 ¹ / ₁₆ -12 U.N. | 1 ¹ / ₁₆ -12 U.N. | 1.375 | 1.500 | 1.675 | 4500 | 0.609 |
| SS 16 MJB 16 X MJ 16 | 4.930 | 2.650 | 1 ⁵ / ₁₆ -12U.N. | 1 ⁵ / ₁₆ -12U.N. | 1.625 | 1.750 | 1.917 | 4000 | 0.827 |
| SS 20 MJB 20 X MJ 20 | 5.290 | 2.850 | 1 ⁵ / ₈ -12 U.N. | 1 ⁵ / ₈ -12 U.N. | 1.875 | 2.125 | 2.357 | 4000 | 1.078 |

Male O-Ring (O.R.B.) X Male J.I.C. (37°)

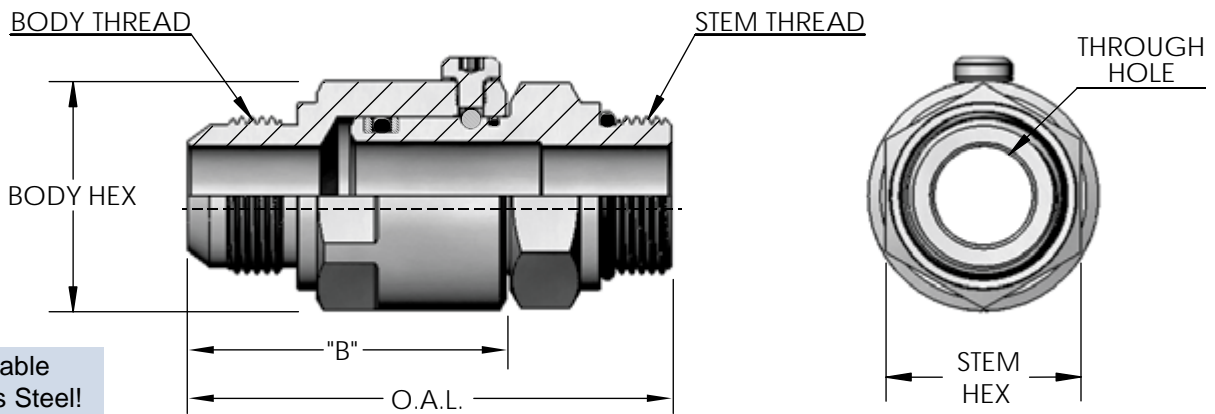

| PART NUMBER | O.A.L | DIM. B | STEM THREAD | BODY THREAD | STEM HEX | BODY HEX/WRENCH | BODY DIA. | MAX P.S.I.G. | THROUGH HOLE |
|---------------------|-------|--------|---|---|----------|-----------------|-----------|--------------|--------------|
| SS 4 MO 4 X MJ 4 | 2.540 | 1.720 | 7/16-20 U.N. | 7/16-20 U.N. | 0.625 | 1.000 | HEX | 5000 | 0.172 |
| SS 4 MO 6 X MJ 6 | 2.540 | 1.720 | 9/16-18 U.N. | 9/16-18 U.N. | 0.750 | 1.000 | HEX | 5000 | 0.250 |
| SS 8 MO 8 X MJ 8 | 2.838 | 1.900 | 3/4-16 U.N. | 3/4-16 U.N. | 1.000 | 1.375 | 1.480 | 5000 | 0.406 |
| SS 8 MO 10 X MJ 8 | 2.960 | 1.900 | 7/8-14 U.N. | 3/4-16 U.N. | 1.000 | 1.375 | 1.480 | 5000 | 0.406 |
| SS 8 MO 10 X MJ 10 | 3.110 | 2.050 | 7/8-14 U.N. | 7/8-14 U.N. | 1.000 | 1.375 | 1.492 | 5000 | 0.484 |
| SS 12 MO 12 X MJ 12 | 3.349 | 2.125 | 1 ¹ / ₁₆ -12 U.N. | 1 ¹ / ₁₆ -12 U.N. | 1.375 | 1.500 | 1.675 | 4500 | 0.609 |
| SS 16 MO 16 X MJ 16 | 4.024 | 2.650 | 1 ⁵ / ₁₆ -12 U.N. | 1 ⁵ / ₁₆ -12U.N. | 1.625 | 1.750 | 1.917 | 4000 | 0.827 |
| SS 20 MO 20 X MJ 20 | 4.315 | 2.850 | 1 ⁵ / ₈ -12 U.N. | 1 ⁵ / ₈ -12 U.N. | 1.875 | 2.125 | 2.357 | 4000 | 1.078 |
| SS 24 MO 24 X MJ 24 | 5.039 | 3.444 | 1 ⁷ / ₈ -12 U.N. | 1 ⁷ / ₈ -12 U.N. | 2.120 | 2.375 | 2.547 | 4000 | 1.312 |

Male Pipe (N.P.T.F.) X Male J.I.C. (37°)

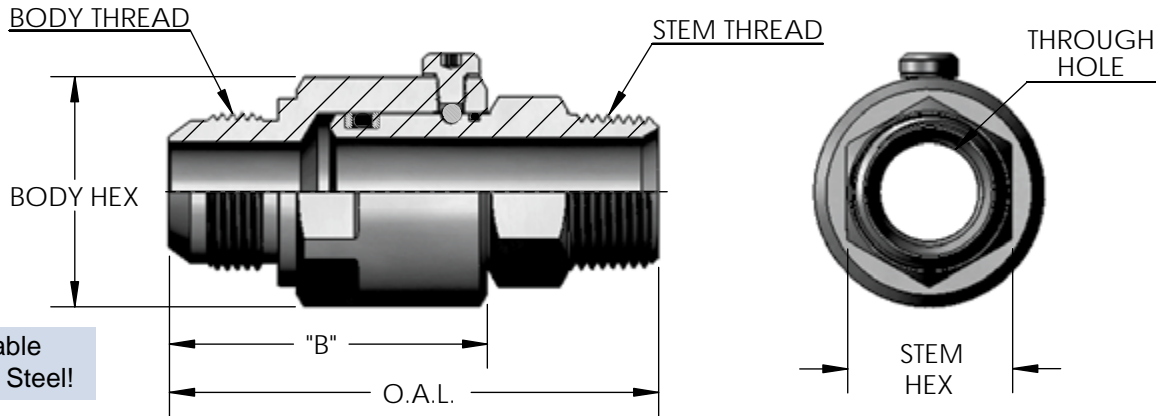

| PART NUMBER | O.A.L. | DIM. B | STEM THREAD | BODY THREAD | STEM HEX | BODY HEX/WRENCH | BODY DIA. | MAX P.S.I.G. | THROUGH HOLE |
|----------------------|--------|--------|-----------------------|----------------|----------|-----------------|-----------|--------------|--------------|
| SS 4 MP 25 X MJ 4 | 2.450 | 1.720 | 1/4-18 N.P.T.F. | 7/16-20 U.N. | 0.625 | 1.000 | HEX | 5000 | 0.180 |
| SS 4 MP 25 X MJ 6 | 2.695 | 1.720 | 1/4-18 N.P.T.F. | 9/16-18 U.N. | 0.625 | 1.000 | HEX | 5000 | 0.250 |
| SS 4 MP 38 X MJ 6 | 2.700 | 1.720 | 3/8-18 N.P.T.F. | 9/16-18 U.N. | 0.750 | 1.000 | HEX | 5000 | 0.250 |
| SS 8 MP 38 X MJ 8 | 3.010 | 1.900 | 3/8-18 N.P.T.F. | 3/4-16 U.N. | 1.000 | 1.375 | 1.480 | 5000 | 0.406 |
| SS 8 MP 38 X MJ 10 | 3.160 | 2.050 | 3/8-18 N.P.T.F. | 7/8-14 U.N. | 1.000 | 1.375 | 1.480 | 5000 | 0.406 |
| SS 8 MP 50 X MJ 8 | 3.090 | 1.900 | 1/2-14 N.P.T.F. | 3/4-16 U.N. | 1.000 | 1.375 | 1.480 | 5000 | 0.406 |
| SS 8 MP 50 X MJ 10 | 3.230 | 2.050 | 1/2-14 N.P.T.F. | 7/8-14 U.N. | 1.000 | 1.375 | 1.480 | 5000 | 0.484 |
| SS 12 MP 75 X MJ 12 | 3.360 | 2.125 | 3/4-14 N.P.T.F. | 1 1/16-12 U.N. | 1.125 | 1.500 | 1.675 | 4500 | 0.609 |
| SS 16 MP 100 X MJ 16 | 4.075 | 2.650 | 1-11 1/2 N.P.T.F. | 1 5/16-12 U.N. | 1.375 | 1.750 | 1.917 | 4000 | 0.827 |
| SS 20 MP 125 X MJ 20 | 4.355 | 2.850 | 1 1/4-11 1/2 N.P.T.F. | 1 5/8-12 U.N. | 1.750 | 2.125 | 2.357 | 4000 | 1.078 |
| SS 24 MP 150 X MJ 24 | 5.119 | 3.444 | 1 1/2-11 1/2 N.P.T.F. | 1 7/8-12 U.N. | 2.000 | 2.375 | 2.557 | 4000 | 1.312 |

Male J.I.C. (37°) X Male J.I.C. (37°)

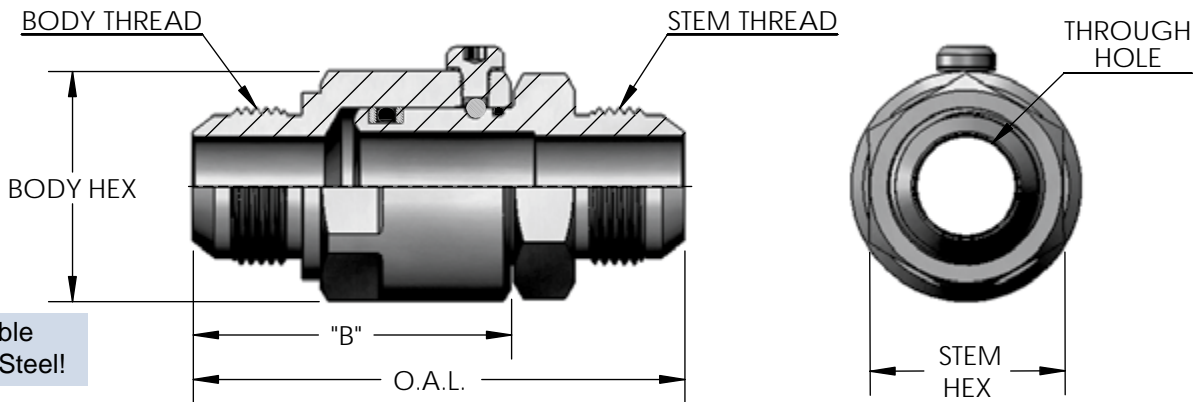

| PART NUMBER | O.A.L. | DIM. B | STEM THREAD | BODY THREAD | STEM HEX | BODY HEX/WRENCH | BODY DIA. | MAX P.S.I.G. | THROUGH HOLE |
|---------------------|--------|--------|----------------|----------------|----------|-----------------|-----------|--------------|--------------|
| SS 4 MJ 4 X MJ 4 | 2.650 | 1.720 | 7/16-20 U.N. | 7/16-20 U.N. | 0.750 | 1.000 | HEX | 5000 | 0.172 |
| SS 4 MJ 6 X MJ 6 | 2.670 | 1.720 | 9/16-18 U.N. | 9/16-18 U.N. | 0.750 | 1.000 | HEX | 5000 | 0.250 |
| SS 8 MJ 8 X MJ 8 | 2.985 | 1.900 | 3/4-16 U.N. | 3/4-16 U.N. | 1.000 | 1.375 | 1.480 | 5000 | 0.406 |
| SS 8 MJ 10 X MJ 10 | 3.235 | 2.050 | 7/8-14 U.N. | 7/8-14 U.N. | 1.000 | 1.375 | 1.480 | 5000 | 0.484 |
| SS 12 MJ 12 X MJ 12 | 3.485 | 2.125 | 1 1/16-12 U.N. | 1 1/16-12 U.N. | 1.375 | 1.500 | 1.675 | 4500 | 0.609 |
| SS 16 MJ 16 X MJ 16 | 4.095 | 2.650 | 1 5/16-12 U.N. | 1 5/16-12 U.N. | 1.625 | 1.750 | 1.917 | 4000 | 0.827 |
| SS 20 MJ 20 X MJ 20 | 4.395 | 2.850 | 1 5/8-12 U.N. | 1 5/8-12 U.N. | 1.750 | 2.125 | 2.357 | 4000 | 1.078 |
| SS 24 MJ 24 X MJ 24 | 5.209 | 3.444 | 1 7/8-12 U.N. | 1 7/8-12 U.N. | 2.125 | 2.375 | 2.557 | 4000 | 1.312 |

Male O-Ring (O.R.B.) X Female J.I.C. (37°)

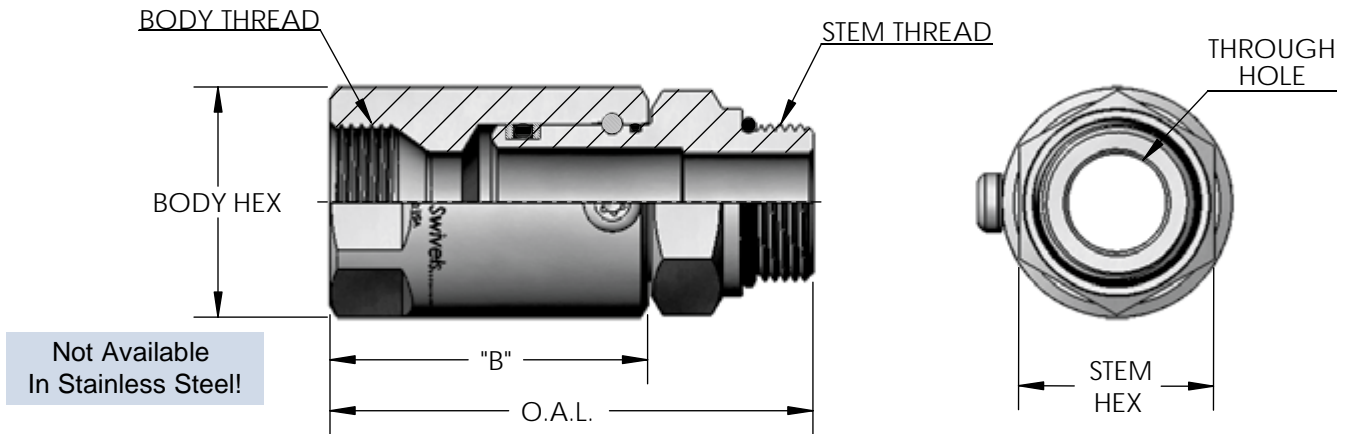

| PART NUMBER | O.A.L. | DIM. B | STEM THREAD | BODY THREAD | STEM HEX | BODY HEX/WRENCH | BODY DIA. | MAX P.S.I.G. | THROUGH HOLE |
|---------------------|--------|--------|----------------|----------------|----------|-----------------|-----------|--------------|--------------|
| SS 4 MO 6 X FJ 6 | 2.640 | 1.820 | 9/16-18 U.N. | 9/16-18 U.N. | 0.750 | 1.000 | HEX | 5000 | 0.250 |
| SS 8 MO 8 X FJ 8 | 2.888 | 1.950 | 3/4-16 U.N. | 3/4-16 U.N. | 1.000 | 1.375 | 1.480 | 5000 | 0.406 |
| SS 8 MO 10 X FJ 10 | 3.110 | 2.050 | 7/8-14 U.N. | 7/8-14 U.N. | 1.000 | 1.375 | 1.480 | 5000 | 0.484 |
| SS 12 MO 12 X FJ 12 | 3.369 | 2.145 | 1 1/16-12 U.N. | 1 1/16-12 U.N. | 1.375 | 1.625 | 1.675 | 4500 | 0.609 |
| SS 16 MO 16 X FJ 16 | 4.020 | 2.646 | 1 5/16-12 U.N. | 1 5/16-12 U.N. | 1.625 | 1.750 | 1.917 | 4000 | 0.827 |
| SS 20 MO 20 X FJ 20 | 4.315 | 2.850 | 1 5/8-12 U.N. | 1 5/8-12 U.N. | 1.875 | 2.125 | 2.357 | 4000 | 1.078 |
| SS 24 MO 24 X FJ 24 | 5.005 | 3.410 | 1 7/8-12 U.N. | 1 7/8-12 U.N. | 2.125 | 2.375 | 2.550 | 4000 | 1.312 |

Female Face Seal (F.F.S.) X Male Face Seal (M.F.S.)

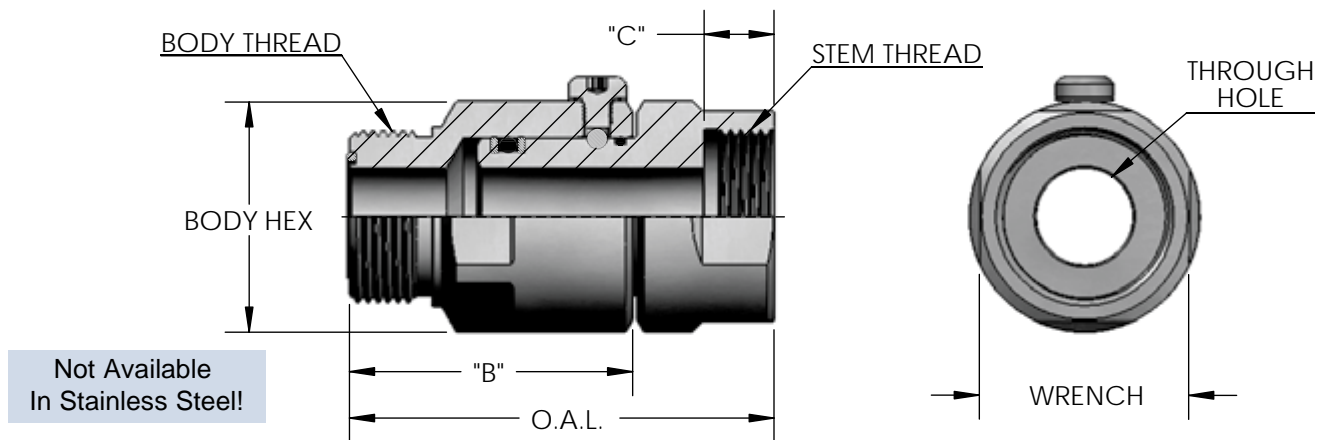

| PART NUMBER | O.A.L. | DIM. B | DIM. C | STEM THREAD | BODY THREAD | WRENCH | BODY HEX/WRENCH | MAX P.S.I.G. | THROUGH HOLE |
|------------------------|--------|--------|--------|-----------------|-----------------|--------|-----------------|--------------|--------------|
| SS 4 FFS 6 X MFS 6 | 2.200 | 1.640 | 0.375 | 11/16-16 U.N. | 11/16-16 U.N. | 0.875 | 1.000 | 5000 | 0.250 |
| SS 8 FFS 8 X MFS 8 | 2.400 | 1.709 | 0.433 | 13/16-16 U.N. | 13/16-16 U.N. | 1.250 | 1.375 | 5000 | 0.390 |
| SS 8 FFS 10 X MFS 10 | 2.550 | 1.815 | 0.504 | 1-14 U.N. | 1-14 U.N. | 1.250 | 1.375 | 5000 | 0.484 |
| SS 12 FFS 12 X MFS 12 | 2.690 | 1.900 | 0.571 | 1 3/16-12 U.N. | 1 3/16-12 U.N. | 1.500 | 1.500 | 4500 | 0.609 |
| SS 16 FFS 16 X MFS 16 | 3.210 | 2.360 | 0.583 | 1 7/16-12 U.N. | 1 7/16-12 U.N. | 1.750 | 1.750 | 4000 | 0.811 |
| SS 20 FFS 20 X MFS 20 | 3.390 | 2.500 | 0.583 | 1 11/16-12 U.N. | 1 11/16-12 U.N. | 2.125 | 2.125 | 4000 | 1.024 |
| SS 24 FFS 24 X MFS 2 4 | 3.950 | 3.050 | 0.583 | 2-12 U.N. | 2-12 U.N. | 2.375 | 2.375 | 4000 | 1.260 |

Male Face Seal (M.F.S.) X Male Face Seal (M.F.S.)

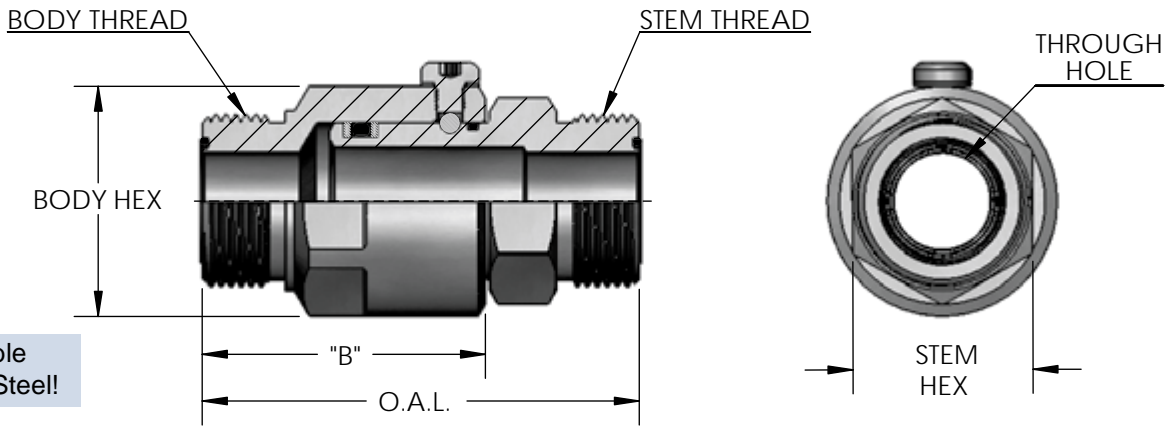

| PART NUMBER | O.A.L. | DIM. B | STEM THREAD | BODY THREAD | STEM HEX | BODY HEX/WRENCH | MAX P.S.I.G. | THROUGH HOLE |
|-----------------------|--------|--------|--|--|----------|-----------------|--------------|--------------|
| SS 4 MFS 6 X MFS 6 | 2.421 | 1.640 | 11/16-16 U.N. | 11/16-16 U.N. | 0.750 | 1.000 | 5000 | 0.250 |
| SS 8 MFS 8 X MFS 8 | 2.633 | 1.709 | 13/16-16 U.N. | 13/16-16 U.N. | 1.000 | 1.375 | 5000 | 0.390 |
| SS 8 MFS 10 X MFS 10 | 2.935 | 1.815 | 1-14 U.N. | 1-14 U.N. | 1.125 | 1.375 | 5000 | 0.484 |
| SS 12 MFS 12 X MFS 12 | 3.120 | 1.900 | 1 ³ / ₁₆ -12 U.N. | 1 ³ / ₁₆ -12 U.N. | 1.250 | 1.500 | 4500 | 0.609 |
| SS 16 MFS 16 X MFS 16 | 3.639 | 2.360 | 1 ⁷ / ₁₆ -12 U.N. | 1 ⁷ / ₁₆ -12 U.N. | 1.500 | 1.750 | 4000 | 0.811 |
| SS 20 MFS 20 X MFS 20 | 3.859 | 2.500 | 1 ¹¹ / ₁₆ -12 U.N. | 1 ¹¹ / ₁₆ -12 U.N. | 1.750 | 2.125 | 4000 | 1.024 |
| SS 24 MFS 24 X MFS 24 | 4.479 | 3.050 | 2-12 U.N. | 2-12 U.N. | 2.125 | 2.375 | 4000 | 1.312 |

Male O-Ring (O.R.B.) X Male Face Seal (M.F.S.)

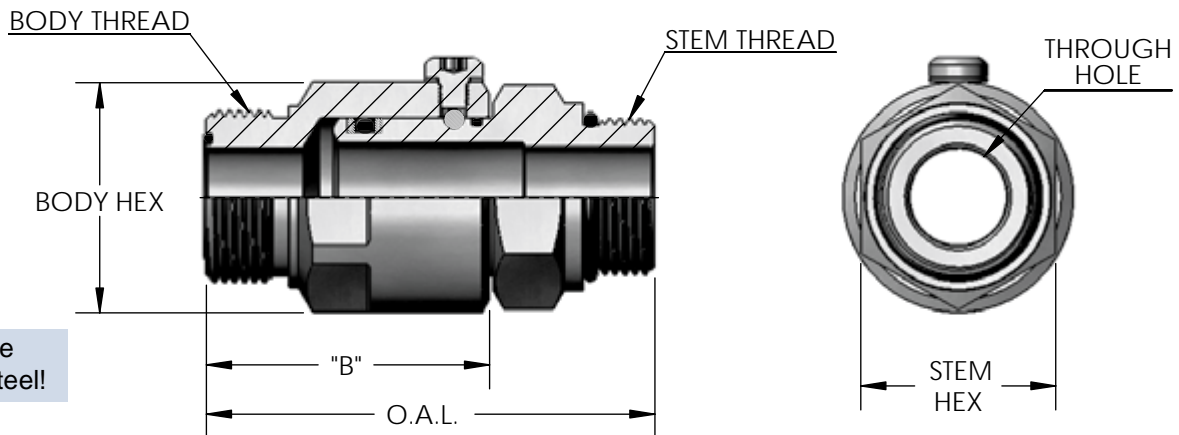

| PART NUMBER | O.A.L. | DIM. B | STEM THREAD | BODY THREAD | STEM HEX | BODY HEX/WRENCH | MAX P.S.I.G. | THROUGH HOLE |
|----------------------|--------|--------|---|--|----------|-----------------|--------------|--------------|
| SS 4 MO 6 X MFS 6 | 2.460 | 1.640 | 9/16-18 U.N. | 11/16-16 U.N. | 0.750 | 1.000 | 5000 | 0.250 |
| SS 8 MO 8 X MFS 8 | 2.647 | 1.709 | 3/4-16 U.N. | 13/16-16 U.N. | 1.000 | 1.375 | 5000 | 0.390 |
| SS 8 MO 10 X MFS 10 | 2.875 | 1.815 | 7/8-14 U.N. | 1-14 U.N. | 1.000 | 1.375 | 5000 | 0.484 |
| SS 12 MO 12 X MFS 12 | 3.124 | 1.900 | 1 ¹ / ₁₆ -12 U.N. | 1 ³ / ₁₆ -12 U.N. | 1.375 | 1.500 | 4500 | 0.609 |
| SS 16 MO 16 X MFS 16 | 3.734 | 2.360 | 1 ⁵ / ₁₆ -12 U.N. | 1 ⁷ / ₁₆ -12 U.N. | 1.625 | 1.750 | 4000 | 0.811 |
| SS 20 MO 20 X MFS 20 | 3.965 | 2.500 | 1 ⁵ / ₈ -12 U.N. | 1 ¹¹ / ₁₆ -12 U.N. | 1.875 | 2.125 | 4000 | 1.024 |
| SS 24 MO 24 X MFS 24 | 4.645 | 3.050 | 1 ⁷ / ₈ -12 U.N. | 2-12 U.N. | 2.125 | 2.375 | 4000 | 1.312 |

Male Face Seal Bulkhead (M.F.S.B.) X Male Face Seal (M.F.S.)

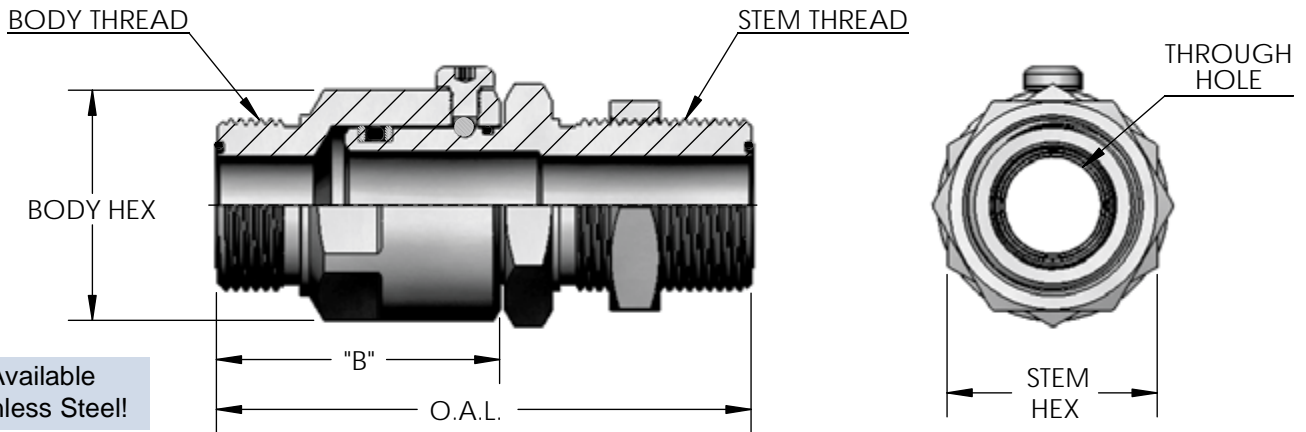

| PART NUMBER | O.A.L. | DIM. B | STEM THREAD | BODY THREAD | STEM HEX | BODY HEX/WRENCH | MAX P.S.I.G. | THROUGH HOLE |
|------------------------|--------|--------|----------------|----------------|----------|-----------------|--------------|--------------|
| SS 4 MFSB 6 X MFS 6 | 3.320 | 1.640 | 11/16-16 U.N. | 11/16-16 U.N. | 1.000 | 1.000 | 5000 | 0.250 |
| SS 8 MFSB 8 X MFS 8 | 3.529 | 1.709 | 13/16-16 U.N. | 13/16-16 U.N. | 1.125 | 1.375 | 5000 | 0.390 |
| SS 8 MFSB 10 X MFS 10 | 3.895 | 1.815 | 1 -14 U.N. | 1-14 U.N. | 1.125 | 1.375 | 5000 | 0.484 |
| SS 12 MFSB 12 X MFS 12 | 3.980 | 1.900 | 13/16-12 U.N. | 13/16-12 U.N. | 1.500 | 1.500 | 4500 | 0.609 |
| SS 16 MFSB 16 X MFS 16 | 4.450 | 2.360 | 17/16-12 U.N. | 17/16-12 U.N. | 1.750 | 1.750 | 4000 | 0.811 |
| SS 20 MFSB 20 X MFS 20 | 4.640 | 2.500 | 111/16-12 U.N. | 111/16-12 U.N. | 2.000 | 2.125 | 4000 | 1.024 |

Stainless Steel Swivels Are Available In Many Types & Sizes



10,000 P.S.I. Female Pipe (N.P.T.F.) X Female Pipe (N.P.T.F.)

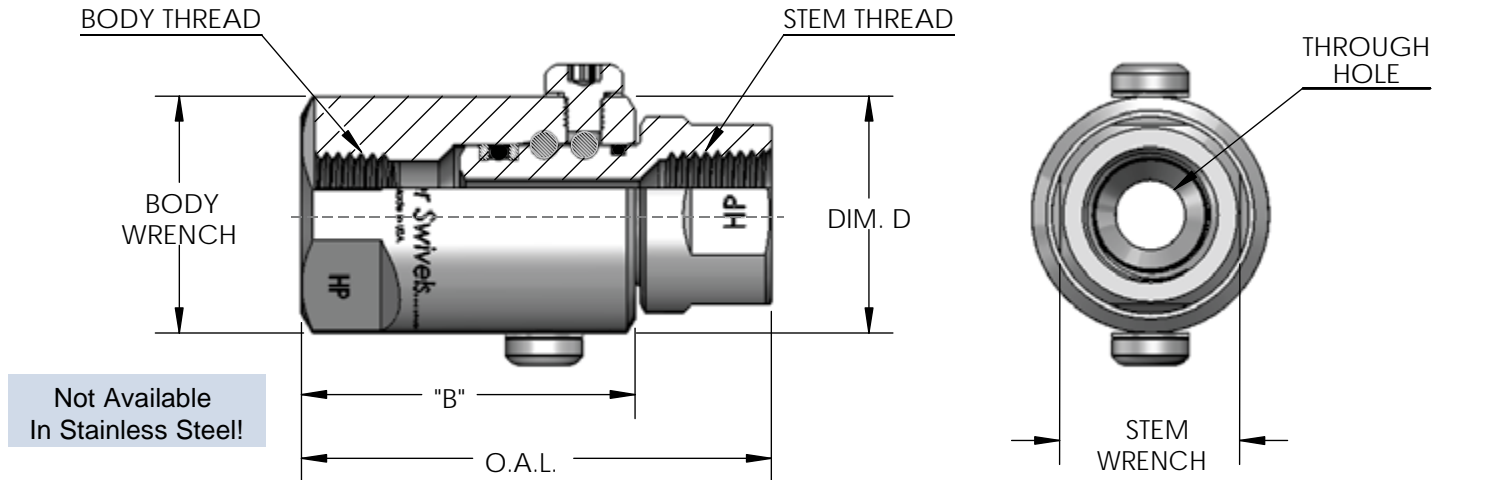

| PART NUMBER | O.A.L. | DIM. B | DIM. D | WRENCH | BODY THREAD | STEM THREAD | STEM WRENCH | MAX P.S.I.G. | THROUGH HOLE |
|-----------------------|--------|--------|--------|--------|-----------------|-----------------|-------------|--------------|--------------|
| SS 8 HP FP 50 X FP 50 | 2.935 | 2.085 | 1.480 | 1.250 | 1/2-14 N.P.T.F. | 1/2-14 N.P.T.F. | 1.125 | 10,000 | 0.437 |

10,000 P.S.I. Male Pipe (N.P.T.F.) X Female Pipe (N.P.T.F.)

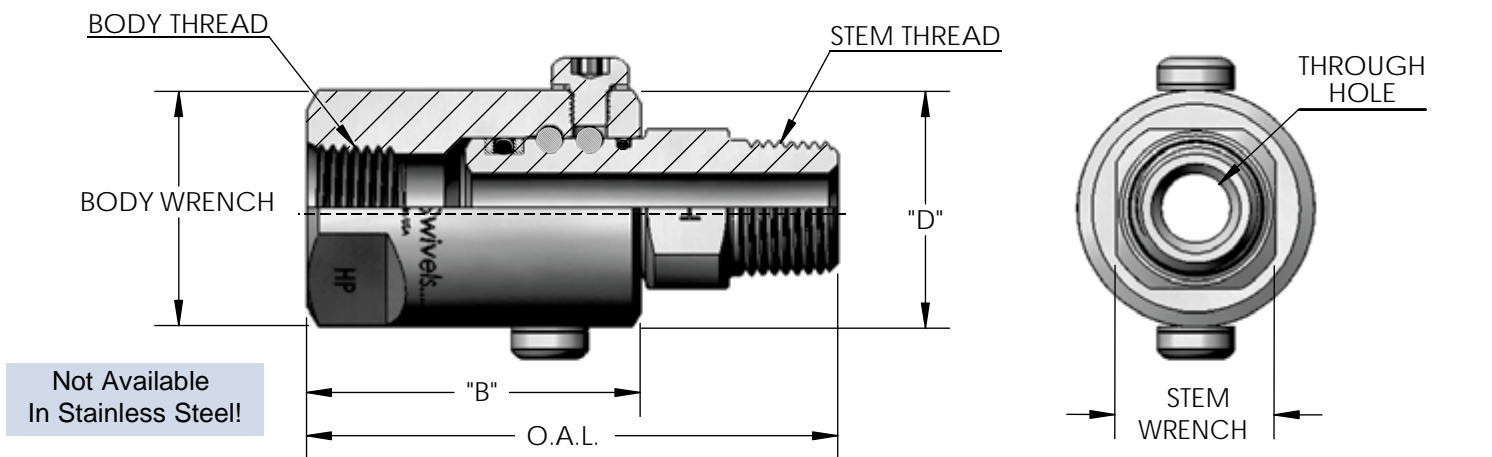

| PART NUMBER | O.A.L. | DIM. B | DIM. D | WRENCH | BODY THREAD | STEM THREAD | STEM WRENCH | MAX P.S.I.G. | THROUGH HOLE |
|-----------------------|--------|--------|--------|--------|-----------------|-----------------|-------------|--------------|--------------|
| SS 8 HP MP 50 X FP 50 | 3.070 | 2.085 | 1.480 | 1.250 | 1/2-14 N.P.T.F. | 1/2-14 N.P.T.F. | 1.000 | 10,000 | 0.437 |

Hydraulic Inline and 90° Live Swivels Seal Rebuilding Kit Instructions

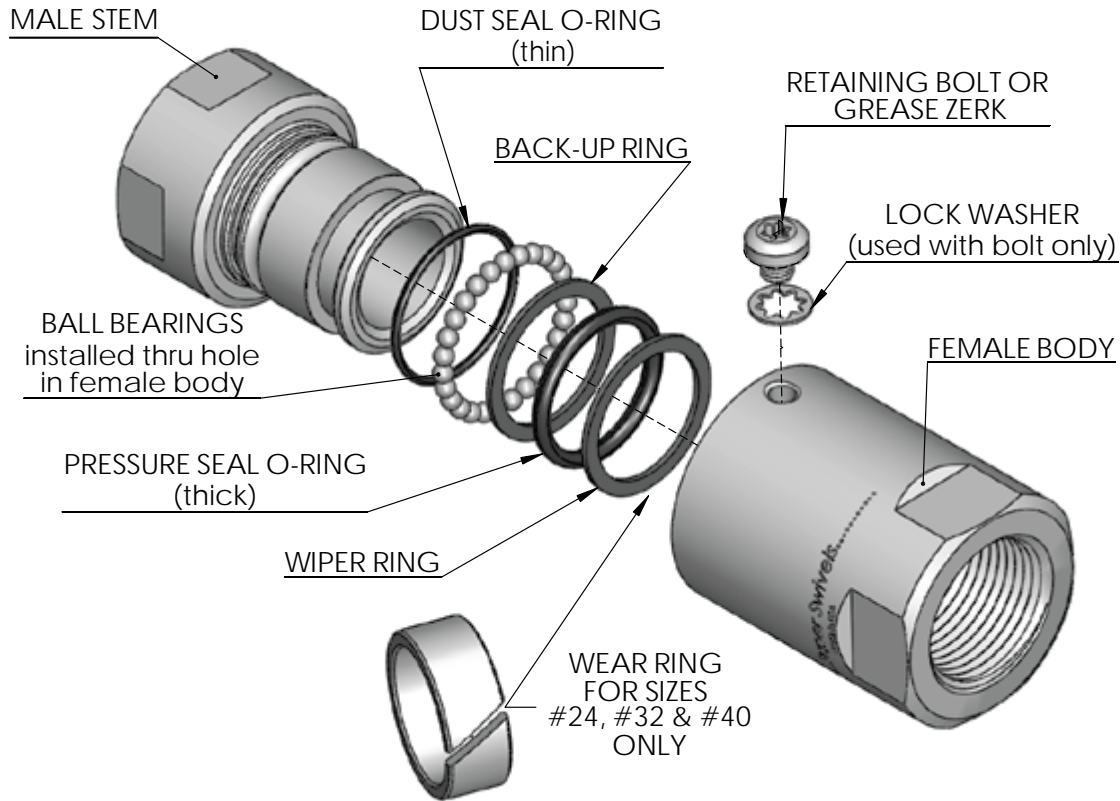

1. Remove retaining bolt or grease zerk (some models have a permanent grease zerk).
2. Wash swivel in solvent and rotate while immersed to remove grease from the ball bearing groove.
3. Remove ball bearings by rotating swivel with ball loading hole pointed downward. If remaining grease in ball groove prevents balls from falling free when centered over loading hole, tap swivel on work bench with loading hole facing down on bench.
4. With all ball bearings removed (check by rotating while looking into ball loading hole), pull the two halves apart and discard old rings, ball bearings and seals.
5. Clean and dry swivel thoroughly, install new seal and wear rings when required, and lubricate the female bore and male outside diameter before assembly. Load retainer ball bearings and install grease zerk (a temporary zerk is provided for models with a retaining bolt). Use lithium based grease with moly (do not over grease).

Note: The temporary grease zerk must be removed and replaced with the original retaining bolt and new lock washer on swivels which didn't originally have a permanent grease zerk.

Switch Your Swivel![®]