

SRF

COMPACT
SUCTION & RETURN HOSE



RECOMMENDED FOR:

Petroleum and water base hydraulic fluids in suction lines or in low pressure return lines. Small bend radius is an advantage in installations where space is minimal. (Tighter Bend Radius than SAE 100R4)

PERFORMANCE:

Meets or Exceeds the Performance Requirements of: AS 3791 100R4, SAE 100R4.

TUBE:

Black, oil resistant synthetic rubber.

REINFORCEMENT:

Textile reinforcement with spiral wire to prevent collapsing.

COVER:

Black, oil resistant and abrasion resistant synthetic rubber.

TEMPERATURE RANGE:

From -40°C to +100°C (-40°F to +212°F).

For water, emulsions etc. see page 57.

WORKING PRESSURE:

Maximum working pressures are based on 4:1 safety factor (maximum working pressure to minimum burst pressure).

COUPLINGS:

Working pressure shown is for hose performance capabilities. Performance of a hose assembly depends on couplings used.

- For Suction Applications, and Low Pressure Delivery (up to 25% of Maximum Working Pressure).**

33000 SERIES COUPLINGS WITH RSC CLAMP 33000 Series

3300 Series Couplings require a suitable clamp around the outside of the hose. Refer to RYCO RSC Clamps shown below.

- For Suction Applications, and High Pressure Delivery (up to 100% of Maximum Working Pressure).**

SRF - DEFIANT COMPACT SUCTION AND RETURN HOSE																
PART NO	HOSE SIZE	NOMINAL HOSE ID		NOMINAL HOSE OD		MAXIMUM WORKING PRESSURE		MINIMUM BURST PRESSURE		MINIMUM BEND RADIUS		VACUUM RATING		AVERAGE WEIGHT		
Hose	DN	Dash	mm	inch	mm	inch	bar	psi	bar	psi	mm	inch	mmHg	inHg	kg/m	lb/ft
SRF12	19	-12	19,1	3/4	31,5	1.24	21	300	84	1200	63	2.5	635	25	0,82	0.55
SRF16	25	-16	25,4	1	40,0	1.57	17	250	68	1000	75	2.9	635	25	1,00	0.67
SRF20	31	-20	31,8	1.1/4	46,5	1.83	14	200	56	800	100	3.9	635	25	1,19	0.80
SRF24	38	-24	38,1	1.1/2	53,1	2.09	10	150	40	600	125	4.9	635	25	1,39	0.93
SRF32	51	-32	50,8	2	65,5	2.58	7	100	28	400	150	5.9	635	25	1,94	1.30

HOSE PART NO	CLAMP PART NO	CLAMP ADJUSTMENT RANGE	RECOMMENDED TIGHTENING TORQUE	
		d mm	N.m	ft.lbf
SRF12	RSC-3134	31 to 34	20	15
SRF16	RSC-3740*	37 to 40	20	15
	RSC-4043*	40 to 43	20	15
SRF20	RSC-4347*	43 to 47	20	15
	RSC-4751*	47 to 51	20	15
SRF24	RSC-5155	51 to 55	20	15
SRF32	RSC-6368	63 to 68	25	18

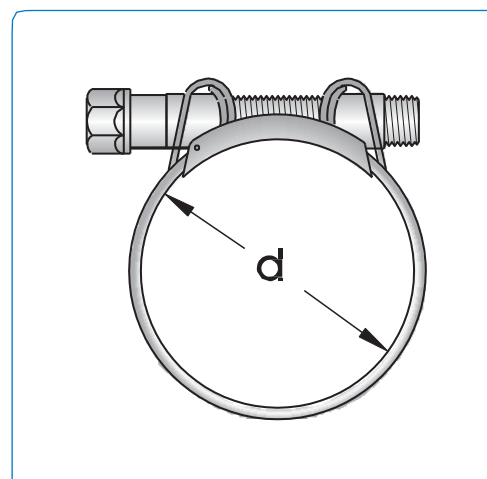

NOTE: For sizes -20, -24 & -32, use RYCO SRF Hose.

*Due to the manufacturing tolerance on outside diameter of the hose and the range of adjustment of the clamp, it is necessary to confirm correct clamp at time of assembly.