

DYNAMIC

FLUID COMPONENTS, INC.



Dynamic Fluid Components, Inc. present their range of products for the hydraulic, pneumatic, process, petro chemical and other allied industries.

Products detailed in this catalog include pressure, vacuum and compound gages, test instruments, test points and probes, valves and hydraulic reservoir accessories.

The Dynamic Fluid Components warehouses, located in West Union, SC and Ceres, CA, offer most of the catalog products from stock. Their extensive network of distributors and representatives are ready to serve you.

GAGES

- Section 1

Page 4



1½" to 2½" Dry Utility Pressure Gages	5-6
1½" to 2½" Glycerine Filled Pressure Gages	7-8
4" S.S. Case Glycerine Filled Pressure Gages	9-10
2½" to 6" All Stainless Steel Pressure Gages	11-12
6" All Stainless Steel Test Gages	13
Gage Protection & Snubbers	14

TEST POINTS & HOSE ASSEMBLIES - Section 2 Page 15



Test Point Plugs and Probes	16-17
JIC Hose Couplings	18
Hydra-Test Flexible Hose Assemblies	18
Hydra-Test End Fittings	19

HYDRAULIC VALVES - Section 3 Page 20



2 and 3-Way High Pressure Ball Valves	21-22
Locking Handle Kits	23
Carbon Steel Check Valves	24
Flow Control Valves	25
Needle Valves	26
High Pressure Needle Valves	27

RESERVOIR ACCESSORIES - Section 4 Page 30



Screw on Breathers	31
Filter Filler Breathers	32

Section 1

PRESSURE GAGES



General Specifications for Standard Pressure Gages

The maximum working pressures of standard gages should not exceed 75% of full scale for constant pressure applications, or 66% of full scale for pulsating pressures.

Normal overpressures allowed are 1.25 times FSV for ranges up to 1,000 psi; 1.15 times FSV for ranges between 1,000 and 10,000 psi; 1.10 times FSV for higher pressures.

Glycerine is used as standard in most Dynamic filled gages.

Neither glycerine nor silicone should be used in applications involving oxygen, chlorine, nitric acid, hydrogen peroxide or other oxidizing agents.

Dynamic filled gages include a dual relief valve/blowout disc for operating safety.

Dial face includes black (psi) and red (bar) scales or black (psi) and red (kPa) scales.

Table of Contents

<u>Product</u>	<u>Page No.</u>
Series CDS Dry Gages.....	5-6
Series CF Filled Gages	7-8
Series PDLC Filled Low Cost Gages.....	9
Series CF 4 Inch Filled Gages.....	10
Series PDSS Stainless Steel Gages	11-12
Series PDTG Test Gages	13
Gauge Protection & Snubbers.....	14

CDS Dry Gages 1 1/2 to 2 1/2 Inch Stem & Center Back Mount

- Steel Case - CDS Series
- Phosphor Bronze Bourdon Tube
- Vacuum to 6,000 PSI Range
- Dual Scale PSI & BAR (KPA referenced)
- Accuracy ± 1.6% FSD
- Temperature Range -40° to 180° F
- Built in Snubber
- Bronze Connection



INSTALLATION DATA

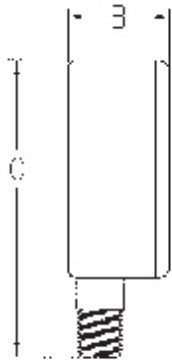

Style A

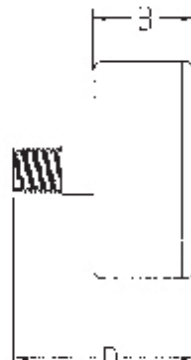

Style D

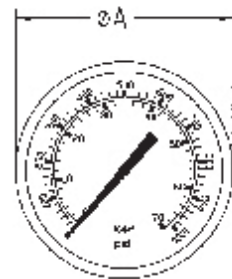

Size	A	B	C	D	E
1 1/2	1.62	.90	2.26	1.50	.95
2	2.00	1.08	2.81	1.80	1.06
2 1/2	2.45	1.05	3.22	1.75	1.03

Ordering Example: **CDS** - **1** **P** - **140** **A**

Model
CDS dry
steel case

Size
*4 - 1 1/2" dia.
5 - 2" dia.
1 - 2 1/2" dia.

Type
P - Pressure
V - Vacuum
C - Compound

Range
002 - 30"Hg - 30 psi
000 - 30"Hg - 0 psi
001 - 15 psi
002 - 30 psi
004 - 60 psi
007 - 100 psi
010 - 160 psi
015 - 200 psi
020 - 300 psi
040 - 600 psi
070 - 1000 psi
100 - 1500 psi
140 - 2000 psi
210 - 3000 psi
280 - 4000 psi
350 - 5000 psi
420 - 6000 psi

Style
A - stem
D - ctr. back

Port Sizes 1 1/2".....1/8 npt standard
2 - 2 1/2".....1/4 npt standard
1/8 npt avail. w/min. order
add -8N to end of part no.

CDS Dry Gages 1 1/2 to 2 1/2 Inch Panel Clamp & Panel Flange Mount

- Steel Case
- Phosphor Bronze Bourdon Tube
- Vacuum to 6,000 PSI Range
- Dual Scale PSI & BAR (KPA referenced)
- Accuracy $\pm 1.6\%$ FSD
- Temperature Range -40° to 180° F
- Built in Snubber
- Bronze Connection



INSTALLATION DATA

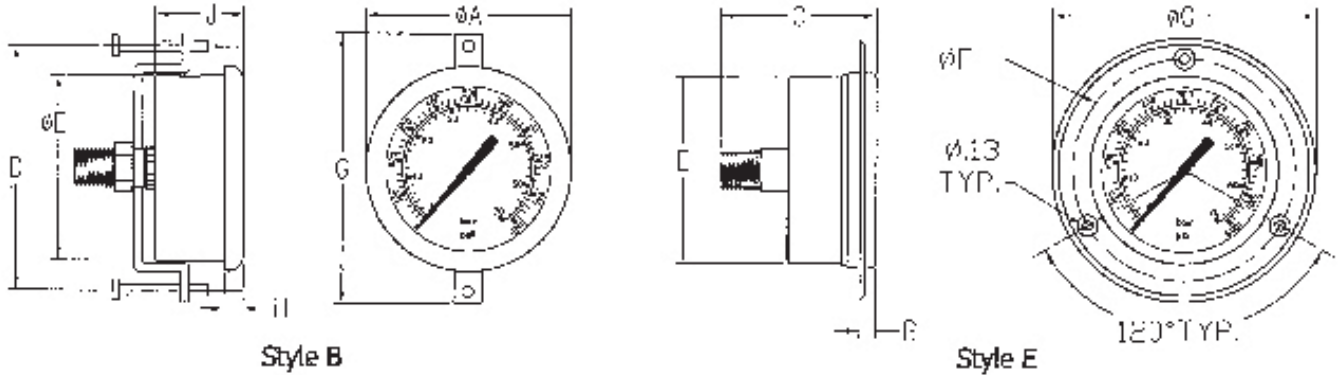

Size	A	B	C	D	E	F	G	H	J
1 1/2	1.81	-	1.75	1.80	1.61	-	-	.18	1.03
2	2.25	.20	1.75	2.28	2.05	2.45	2.80	.21	1.15
2 1/2	2.68	.20	1.75	3.14	2.40	2.85	3.29	.247	1.17

Ordering Example: **CDS** - **1** **P** - **140** **B**

<p>Model CDS dry steel case</p>	<p>Size 4 - 1 1/2" dia. 5 - 2" dia. 1 - 2 1/2" dia.</p>	<p>Type P - Pressure V - Vacuum C - Compound</p>	<p>Range 002 - 30"Hg - 30 psi 000 - 30"Hg - 0 psi 001 - 15 psi 002 - 30 psi 004 - 60 psi 007 - 100 psi 010 - 160 psi 015 - 200 psi 020 - 300 psi 040 - 600 psi</p>	<p>070 - 1000 psi 100 - 1500 psi 140 - 2000 psi 210 - 3000 psi 280 - 4000 psi 350 - 5000 psi 420 - 6000 psi</p>	<p>Style B - panel clamp E - flange</p>
--	--	---	---	---	--

Port Sizes 1 1/2"1/8 npt standard
2 - 2 1/2" ...1/4 npt standard
1/8 npt avail. w/min. order
add -8N to end of part no.

*Note: 1 1/2 inch dia. limited to 5000 psi

CF Series 1 1/2 - 2 and 2 1/2 Inch Glycerine Filled

- Stainless Steel Case & Bezel
- Phosphor Bronze Bourdon Tube
- Vacuum to 10,000 PSI Range
- Dual Scale PSI & BAR (KPA referenced)
- Accuracy ± 1.6% FSD
- Temperature Range -40° to 180° F
- Bronze Connection



INSTALLATION DATA

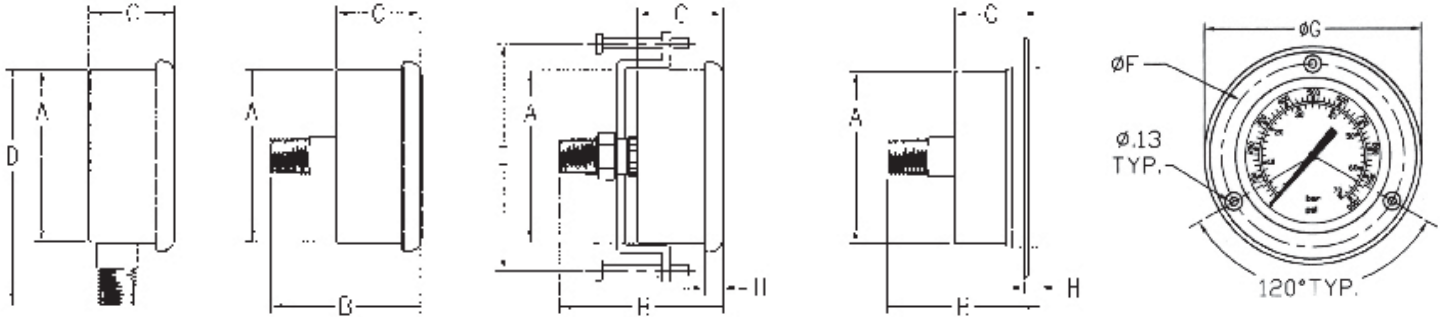

Size	A	B	C	D	E	F	G	H
1 1/2	1.58	1.98	1.02	2.47	2.30	-	-	.20
2	1.98	2.21	1.19	3.05	2.28	2.40	2.76	.24
2 1/2	2.40	2.25	1.18	3.45	3.18	2.90	3.42	.25

Ordering Example: **CF** - **1** **P** - **004** - **A**

Model	Size	Type	Range	Style
CF	1 - 2 1/2 dia.	C - compound	002 - 30" Hg -30psi	A - stem
Designation	5 - 2 dia.	V - vacuum	000 - 30" Hg - 0psi	B - panel clamp
for glycerine	*4 - 1 1/2 dia.	P - pressure	001 - 15 psi	D - ctr. back
filled gages			002 - 30 psi	E - panel flange
			004 - 60 psi	
			007 - 100 psi	
			010 - 160 psi	
			015 - 200 psi	
			020 - 300 psi	
			040 - 600 psi	
			070 - 1000 psi	
			100 - 1500 psi	
			140 - 2000 psi	
			210 - 3000 psi	
			280 - 4000 psi	
			350 - 5000 psi	
			420 - 6000 psi	
			700 - 10,000 psi	

*Note: 1 1/2 inch available only as a center back mount port size - 1/8 NPT. Limited to 5000 PSI.

Port Sizes for 2" and 2 1/2" are 1/4 NPT
Special sizes subject to minimum order qty.

CF Series 2 1/2 Inch with SAE Swivel

- Stainless Steel Case & Bezel
- Phosphor Bronze Bourdon Tube
- Vacuum to 10,000 PSI Range
- Dual Scale PSI & BAR (KPA referenced)
- Accuracy ± 1.6% FSD
- Temperature Range -40° to 180° F
- SAE 7/16-20 Bronze Connection



INSTALLATION DATA

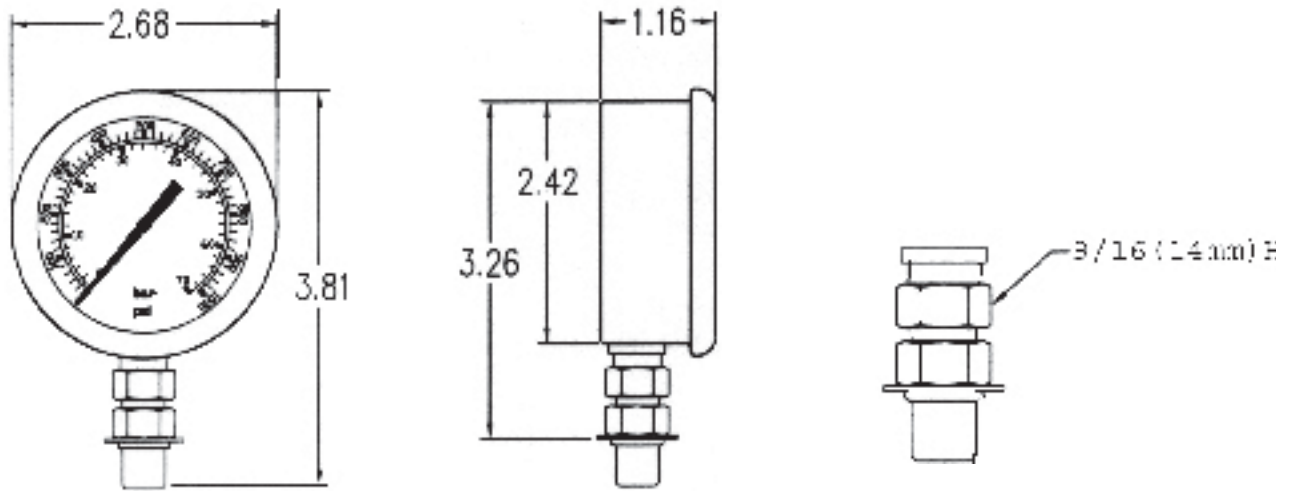

Ordering Example: CF - 1 P - 004 - A - SAE

Model	Size	Type	Range		Style	Port
CF	1 - 2 1/2 dia.	C - compound	002 - 30" Hg -	070 - 1000 psi	A - stem	7/16-20 SAE
Designation for glycerine filled gage		V - vacuum	30psi	100 - 1500 psi		
		P - pressure	000 - 30" Hg - 0psi	140 - 2000 psi		
			001 - 15 psi	210 - 3000 psi		
			002 - 30 psi	280 - 4000 psi		
			004 - 60 psi	350 - 5000 psi		
			007 - 100 psi	420 - 6000 psi		
			010 - 160 psi	700 - 10,000 psi		
			015 - 200 psi			
			020 - 300 psi			
			040 - 600 psi			

PDLC Series 4 Inch Glycerine Filled

**LOW COST
4 INCH GAGE**

- Stainless Steel Case & Bezel
- Phosphor Bronze Bourdon Tube
- Up to 10,000 PSI Range
- Dual Scale PSI & Bar (KPA referenced)
- Accuracy $\pm 2\%$ FSD
- Temperature Range -40° to 180° F
- Bronze connection
- Stem, Center Back & Panel Clamp



INSTALLATION DATA

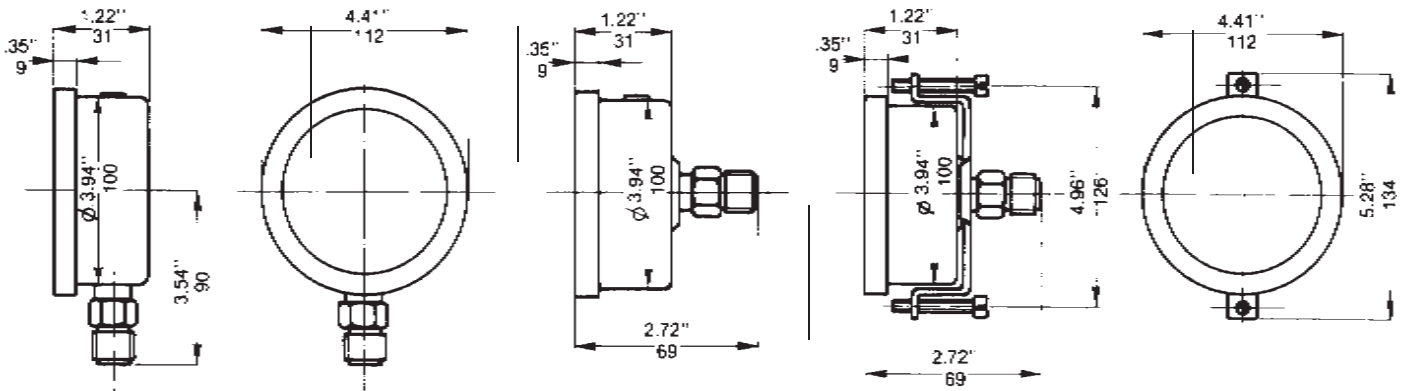

Style A

Style D

Style B

Ordering Example: PDLC - 2 P - 070 - A

Model

Designation for low cost 4 inch gages

Size

2 - 4" dia.

Type

P - pressure

Range

001 - 15 psi	070 - 1000 psi
002 - 30 psi	100 - 1500 psi
004 - 60 psi	140 - 2000 psi
007 - 100 psi	210 - 3000 psi
010 - 160 psi	280 - 4000 psi
015 - 200 psi	350 - 5000 psi
020 - 300 psi	420 - 6000 psi
040 - 600 psi	700 - 10,000 psi
070 - 1000 psi	

Style

A - stem
B - panel clamp
D - ctr. back

**All Connections
1/4" NPT**

CFC Series 4 Inch Glycerine Filled



- Stainless Steel Case & Bezel
- Phosphor Bronze Bourdon Tube
- Vacuum to 10,000 PSI Range
- Dual Scale PSI & Bar (KPA referenced)
- Accuracy $\pm 1.6\%$ FSD
- Temperature Range -40° to 180° F
- Bronze connection
- Stem, Lower Back Panel Mount & Front Flange
- Built in Relief Valve & Snubber

INSTALLATION DATA

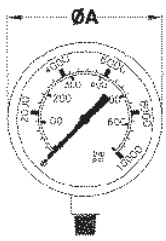

Style A

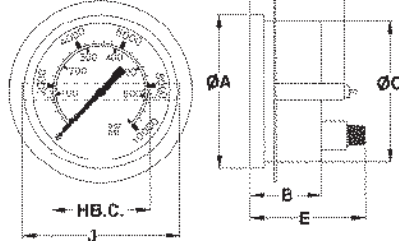

Style B & D

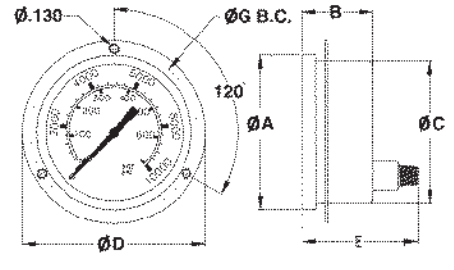

Style E

Dimensional Table for style A (inches)

F	A	B	C	E	Weight
1/2 NPT	4.28	1.84	3.90	3.13	1.80
1/4 NPT	4.28	1.84	3.90	3.13	1.80

Dimensional Table for style B & E (inches)

F	A	B	C	D	E	G	H	J	K	Weight
1/2 NPT	4.28	1.89	3.90	5.16	3.15	4.53	2.76	4.28	2.55	1.80
1/4 NPT	4.28	1.89	3.90	5.16	3.15	4.53	2.76	4.28	2.55	1.80

NOTE: 1/4 NPT is standard for 0/600 psi range and below

1/2 NPT is standard for 1000 psi range and above

Ordering Example: **CFC - 2 P - 070 - A**

Model	Size	Type	Range	Style
Designation	2 - 4" dia.	C - compound	002 - 30" Hg -30psi	A - stem
liquid filled gages		V - vacuum	000 - 30" Hg - 0psi	B - panel clamp
		P - pressure	001 - 15 psi	D - lower back
			002 - 30 psi	E - panel flange
			004 - 60 psi	
			007 - 100 psi	
			010 - 160 psi	
			015 - 200 psi	
			020 - 300 psi	
			040 - 600 psi	
			070 - 1000 psi	
			100 - 1500 psi	
			140 - 2000 psi	
			210 - 3000 psi	
			280 - 4000 psi	
			350 - 5000 psi	
			420 - 6000 psi	
			700 - 10,000 psi	

1-1/2" - 2 1/2" Stainless Steel Liquid Filled & Dry

- 304 SS Case
- 316 SS Connection
- 316 SS Bourdon Tube
- Vacuum to 15,000 psi
- Dual Scale PSI & BAR
- Accuracy $\pm 1.6\%$
- Ambient Temperature -13° F to 150° F
- Process Temperature max. + 750°F
- Liquid Filled & Dry



INSTALLATION DATA

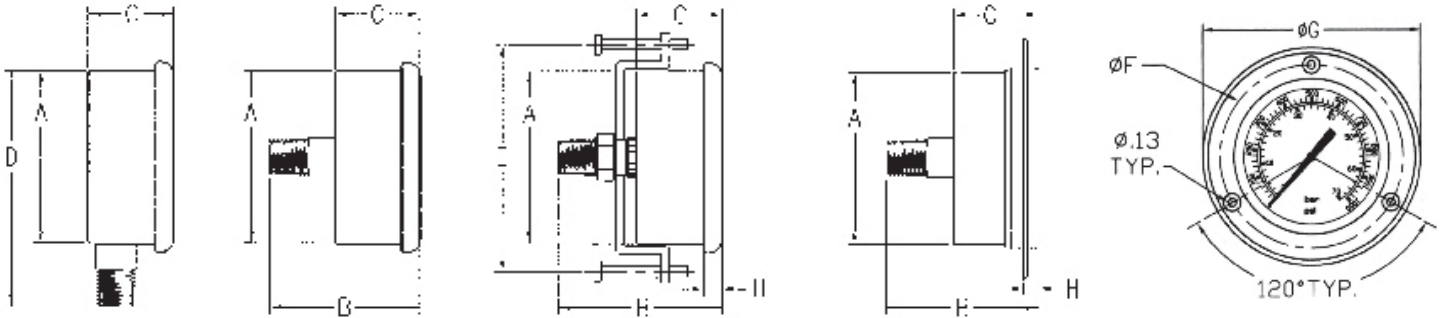

Size	A	B	C	D	E	F	G	H
1 1/2	1.58	1.98	1.02	1.247 dia.	2.30	-	-	.20
2	1.98	2.21	1.19	1.534 dia.	2.28	2.40	2.76	.24
2 1/2	2.40	2.25	1.18	1.811 dia.	3.18	2.90	3.42	.25

Ordering Example: **PDSS - 1 P - 010 - A - 001**

Model	Size	Type	Range	Style	Options
Designation for all stainless steel gages	4 - 1-1/2" 5 - 2" 1 - 2-1/2"	C - compound V - vacuum P - pressure	002 - 30" Hg -30psi 000 - 30" Hg - 0psi 001 - 15 psi 002 - 30 psi 004 - 60 psi 007 - 100 psi 010 - 160 psi 015 - 200 psi 020 - 300 psi 040 - 600 psi	070 - 1000 psi 100 - 1500 psi 140 - 2000 psi 210 - 3000 psi 280 - 4000 psi 350 - 5000 psi 420 - 6000 psi 700 - 10,000 psi 800 - 15,000 psi	A - stem B - panel clamp D - ctr. back E - panel flange 001 - Glycerine filled 002 - Dry

PDSS Series 4 and 6" Stainless Steel Liquid Filled & Dry



- 304 SS Case
- 316 SS Connection
- 316 SS Bourdon Tube
- Vacuum to 30,000 psi
- Dual Scale PSI & KPA
- Accuracy $\pm 1.0\%$
- Ambient Temperature -13° F to 150° F
- Process Temperature max. + 750°F
- Liquid Filled & Dry

Dimensions - 4 & 6" Dry Model Installations Shown

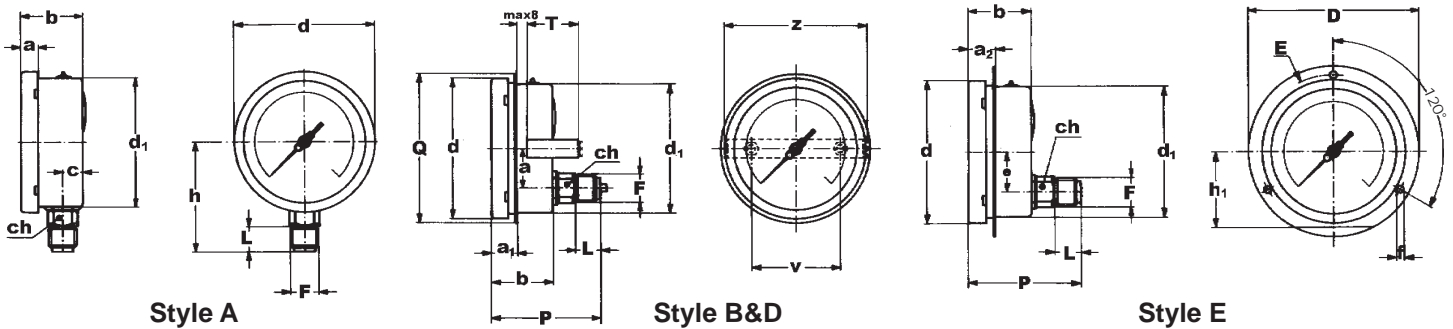

Style A

Size	Range	F	a	b	b ¹	c	c ¹	d	d ¹	D	E	h	h ¹	ch	Weight
4"	0-30,000 psi	¼or½	.57	1.99	2.15	.61	.77	4.41	3.98	5.12	4.57	3.43	2.05	.67	2.42 lbs.
6"	0-30,000 psi	½	.65	2.11	2.26	.61	.77	6.54	5.91	7.48	6.89	4.65	3.35	.67	4.95 lbs.

Styles B, D & E

Size	Range	F	a	a ¹	a ²	b	d	d ¹	D	E	e	h ¹	P	T	V	Z	ch	Weight
4"	0-30,000 psi	¼or½	.57	.83	.79	1.99	4.41	3.98	5.12	4.57	1.36	---	3.39	1.63	2.76	4.41	.67	2.42 lbs.
6"	To 1,000 psi	½	.65	.83	.98	2.11	6.54	5.91	7.48	6.89	2.09	3.35	3.50	1.77	4.17	6.10	.67	4.95 lbs.
6"	1500-30,000 psi	½	.65	.83	.98	2.11	6.54	5.91	7.48	6.89	1.36	3.35	3.50	1.77	4.17	6.10	.67	4.95 lbs.

Note: 4" gages 600 psi and below are ¼" NPT. 1000 psi and above are ½" NPT
6" gages ½" NPT standard

Ordering Example: **PDSS - 2 P - 010 - A - 001**

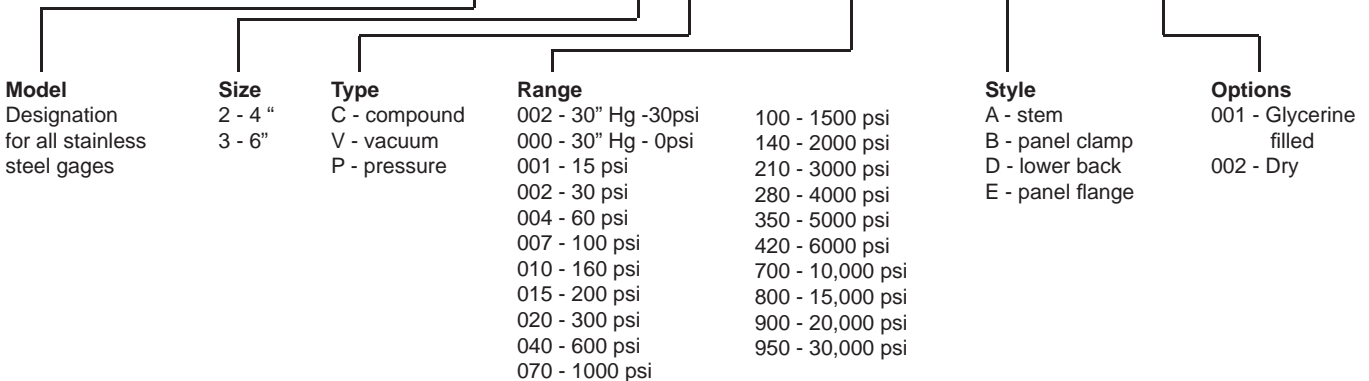

PDTG Test Gages 6" Dry Stem & Panel Mount

- Accuracy ± 0.50 FSV
- 304 SS Case
- SS Bourdon Tube
- Adjustable Pointer is Micrometer Knife Type
- Reinforced Movement is AISI 316
- Maximum Working Pressure 75% FSV
- Temperature Range 60°F to 150°F
- 6" Size
- Mirrored Dial



INSTALLATION DATA

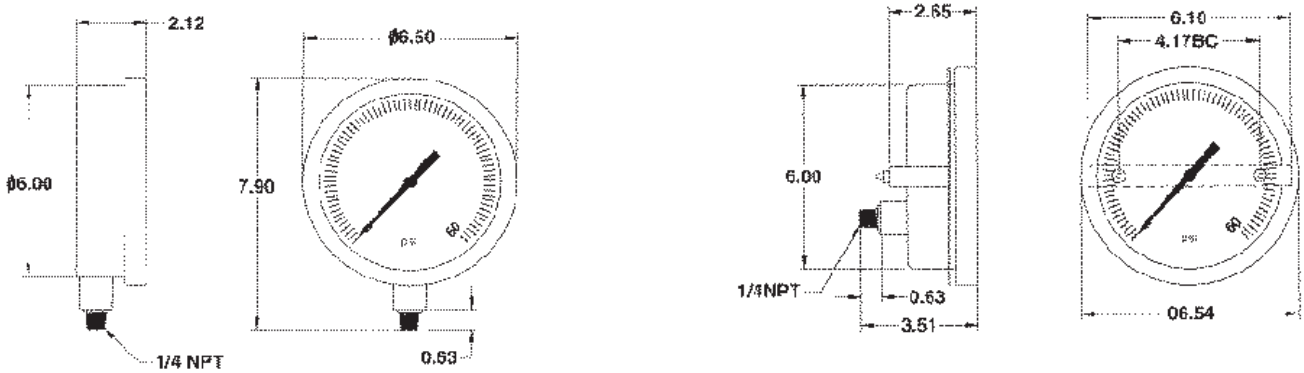

Ordering Example: **PDTG - 3 P - 010 - A - 01**

Model	Size	Type	Range	Style	Options
Designation for PDTG test gage	3 - 6 inch	C - Compound V - Vacuum P - Pressure	002 - 30" Hg -30psi 000 - 30" Hg - 0psi 001 - 15 psi 002 - 30 psi 004 - 60 psi 007 - 100 psi 010 - 160 psi 015 - 200 psi 020 - 300 psi 040 - 600 psi	070 - 1000 psi 100 - 1500 psi 140 - 2000 psi 210 - 3000 psi 280 - 4000 psi 420 - 6000 psi 700 - 10,000 psi 800 - 15,000 psi 900 - 20,000 psi	A - Stem B - Panel Mount (special order only) 01 - Shatterproof lens 02 - 1/4 NPT connection

1/4 NPT connection is standard
Certificate of Calibration Available

Gage Snubbers

By fitting a snubber, a pressure gage is protected from harmful pressure surges and pulsations which would otherwise overload the gage mechanism

MODEL PDD-4 The ¼ NPT snubber has a helically formed oilway with a small orifice through which fluid must pass to reach the gage. This provides a high resistance to smooth out surges and pulses, yet allows rapid responses and steady gage readings.

Model No.	A	B	C	D	E	F	G	Material	Rated Pressure
PDD - 4	¼NPT	.52	.94	.20	.71	.43	.55	Steel	10,000 PSI

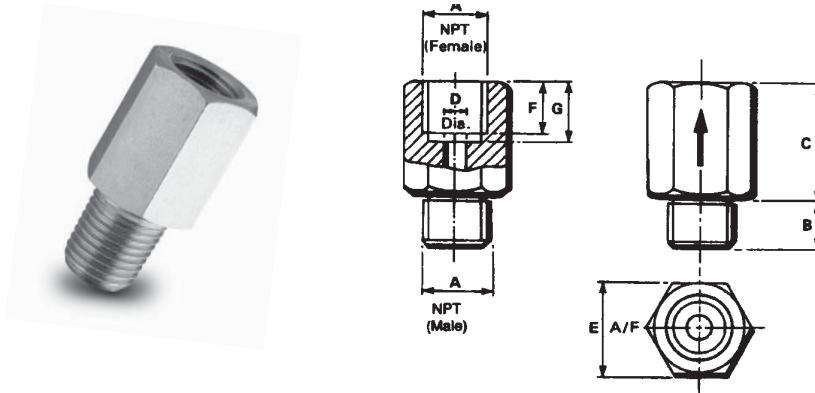

Gage Protectors

Dynamic recommends the use of our Buna N rubber housing gage protector. This saves damage to the gage should it be dropped or bumped.

Order by Part Number: GP40N



Section 2

TEST POINT PLUGS AND PROBES

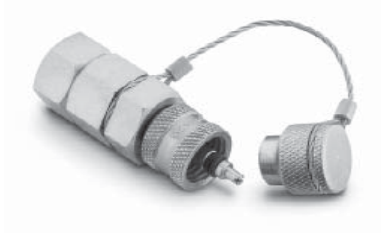

General Information

The need for preventative maintenance of hydraulic systems in general has added to the use of test points throughout the system. This need is answered by the installation of a range of test points, plugs and probes, which can be connected under full system pressure to 6000 psi. Where the introduction of test points is needed, and the hydraulic system uses flexible hydraulic hoses, Dynamic has a range of Hydra-Test hose couplings fitted with test points. For full product data consult the following pages.

Table of Contents

<u>Product</u>	<u>Page No.</u>
Series FTP Test Point Plugs & Probes	16-17
Series HSP Interchangeable Test Points & Plugs	18
Series HSP Hydra Test Hose Couplings	18
Series DHA Remote Test Point Plug Hose Assemblies.....	19

Test Point Plugs

- Dynamic Special Design
- Connects Under Full Pressure
- Rated at 6000 PSI
- All Steel Construction
- Buna Seals are Standard



Dynamic Test point plugs and probes are designed to monitor hydraulic system conditions without system shutdown to connect the pressure gage. These test plugs are fitted as a “standard” into the mobile or industrial application where eventual system monitoring is required.

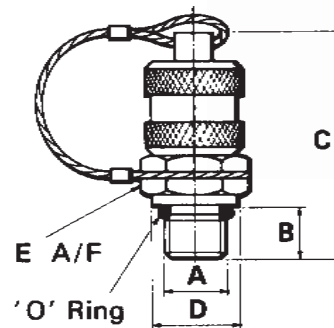
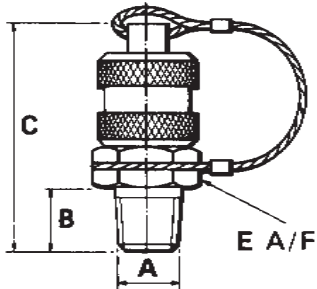

Test Point Plugs (Standard Dynamic Model)

MODEL	A	B	C	D	E	Max. Torque In Lbs.	Weight Lbs.	Seal Kit	
	Thread	Inches	Inches	Inches	Inches			*Buna-N	*Viton
FTP02N	1/8 NPT	0.39	1.81	--	0.75	180	.15	SK115-N	SK115
FTP04N	1/4 NPT	.056	1.87	--	0.82	180	.17	SK115-N	SK115
FTP04S	7/16-20 SAE	.036	1.81	.71	0.75	180	.17	SK115-N	SK115

*Special Order Only

Test Point Probes

Dynamic Standard Probe Model FPPO4N

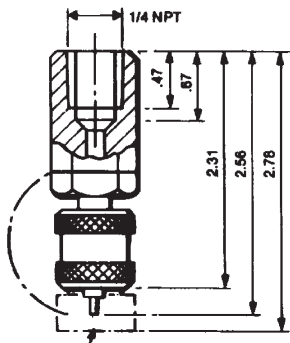

PROBES

Dynamic probes are designed to connect directly to the test point plug. When fitted with the desired pressure gage, the system pressure is released into the gage bourdon tube as the probe opens the test point valve. It can be connected or disconnected under pressure. This provides a precise means to monitor system pressure without turning the system off to test. See page 3 for 2½” pressure gage data.

For complete model with a liquid filled gage add the Model No. to the plug model number. i.e. FPP04N-CF1P-210A is a plug assembly fitted with 0/3000 psi stem gage.

GAGE PROTECTORS

Dynamic recommends the use of a gage protector Buna N rubber housing when using a test point probe. This saves damage to the gage should it be dropped or bumped during the test proceedings. Order by model number GP-40N. See photo above.

DYNAMIC

FLUID COMPONENTS, INC.

- Connects Under Full Pressure
- Rated at 9000 PSI
- All Steel Construction
- Buna Seals are Standard

D1620 Series Test Point Connectors M16 x 2.0

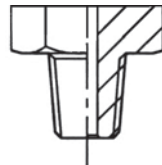
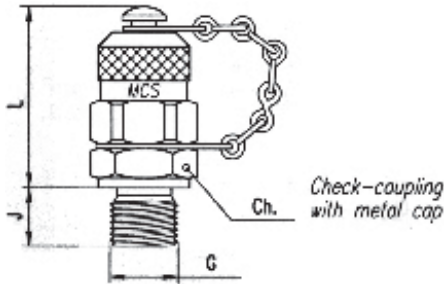

Form C

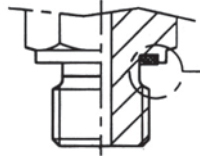

Form E



Form F

Model	Form	Maximum PSI	Ch.	J	G
D1620-01-18-NPT	C	5800	.67	.37	18-NPT
D1620-01-14-NPT	C	9000	.67	.55	14-NPT
D1620-01-04-SAE	F	9000	.67	.43	04-SAE
D1620-01-06-SAE	F	9000	.75	.47	06-SAE
D1620-01-08-SAE	F	9000	.87	.55	08-SAE
D1620-01-M10X1	E	9000	.67	.33	M10X1
D1620-01-M12x1.5	E	9000	.67	.47	M12x1.5
D1620-01-M14x1.5	E	9000	.75	.47	M14x1.5
D1620-01-M16x1.5	E	9000	.87	.47	M16x1.5
D1620-01-18-BSPP	E	9000	.67	.32	18-BSPP
D1620-01-14-BSPP	E	9000	.75	.47	14-BSPP
D1620-01-38-BSPP	E	9000	.87	.47	38-BSPP

*Special Order Only

DGA1620 Series Test Point Probe M16 x 2.0

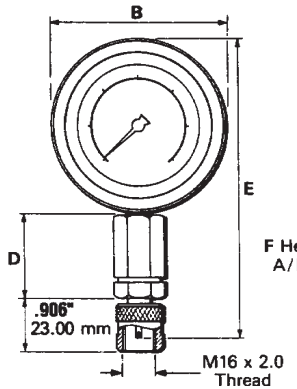

Note: Model No. does not include gage. Dimensions include 2½" dia. gage. See page 22 for gage protection data.

Hydra-Test J.I.C. Hose Couplings

- 6,000 PSI Working Pressure
- Fitted with Hydra-Test Point Plug
- Can be Used With Direct or Remote Test Probes
- For J.I.C. 37° Hose Sizes: 7/16" - 1.7/8" UNF
- Can be Connected and Disconnected at Full System Pressure

Install Hydra-Test J.I.C. Hose Couplings between the female swivel nut of the flexible hose and the fixed male connection. The integral Test Point may be used with Dynamic Test Probes or Test Kits to obtain random pressure and temperature checks during servicing or fault finding. The Fluid Sampling Probe is also compatible.

All probes may be connected and disconnected at full system pressure without fluid loss or ingress of dirt.



Model No.	A		B		C		D		E		F		Weight		Seal Kit	
	U.N.F.	IN	MM	IN	MM	IN	MM	IN	MM	IN	MM	LBS	Kg	*Nitrile	*Viton	
HSP1040-4	7/16"-20	2.01	51.18	1.00	25.40	1.22	30.95	.56	14.28	1.12	28.57	.29	.13			
HSP1040-5	1/2"-20	2.01	51.18	1.00	25.50	1.30	33.13	.62	15.87	1.12	28.57	.31	.14			
HSP1040-6	9/16"-18	2.01	51.18	1.01	25.70	1.36	33.91	.69	17.46	1.12	28.57	.33	.15			
HSP1040-8	3/4"-16	2.01	51.18	1.11	28.30	1.33	33.73	.87	22.22	1.12	28.57	.35	.16			
HSP1040-10	7/8"-14	2.14	54.36	1.23	31.30	1.51	38.45	1.00	25.40	1.37	34.92	.55	.25			
HSP1040-12	1 1/16"-12	2.14	54.36	1.31	33.30	1.64	41.59	1.25	31.75	1.37	34.92	.66	.30			
HSP1040-16	1 5/16"-12	2.30	58.33	1.36	34.60	1.72	43.73	1.50	38.10	1.69	42.86	.95	.43	SK114N	SK114V	
HSP1040-20	1 5/8"-12	2.61	66.33	0.96	24.30	1.77	45.00	2.05	52.00	2.00	50.80	1.71	.78			
HSP1040-24	1 7/8"-12	2.98	75.87	1.08	27.50	1.89	48.00	2.20	56.00	2.22	56.34	1.98	.90			

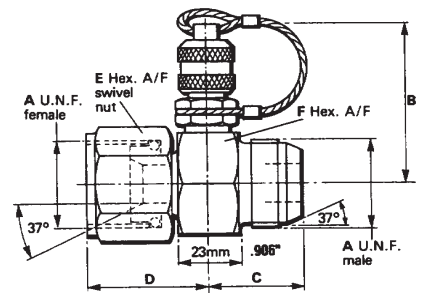

*Special Order Only

Hydra-Test Flexible Hose Assemblies

The DHA series flexible hose series is available fitted with a pressure gage. The assembly is for use with Dynamic Test Plugs, Pipe Couplings and Standpipe adaptors. Together they facilitate pressure readings on a random basis throughout a hydraulic system. Probes may be connected or disconnected with the system at full working pressure without loss of oil or ingress of dirt. Use of Hydra-Test saves the installation of multiple pipework and gages.

ORDERING EXAMPLE:

DHA - **FTP** - **12** - **4F**

Designation
for Dynamic
Hose Assem-

End
Fitting
see codes on
next page

Hose
Length
in inches
see Table 1

End
Fitting
see codes on
next page

Table 1

Hose Lengths (IN)
12
24
36
48
60
72

Please specify in inches if
other lengths are required

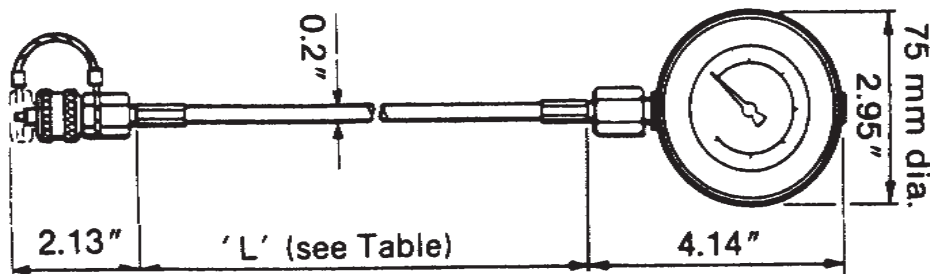

If you require a gage assembled to the hose assembly, please add the gage number to the end of the part number.

DYNAMIC

FLUID COMPONENTS, INC.

Hydra-Test End Fittings

- Optional End Fittings
- Choice of Hose Lengths
- Up to 6000 PSI Working Pressure
- Steel Components Passivated

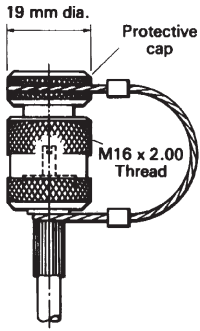

Code HSP

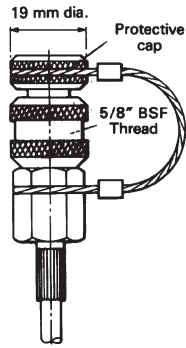

Code FTP

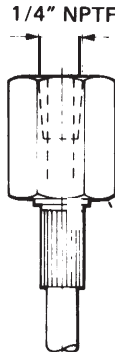

Code 4F

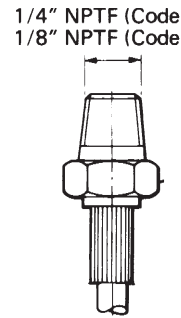

Code 4M
Code 2M

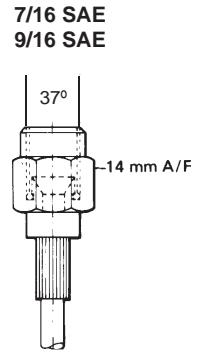

Code 7/16F
Code 9/16F

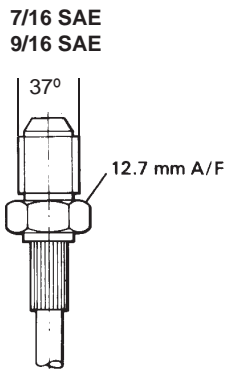

Code 7/16M
Code 9/16M

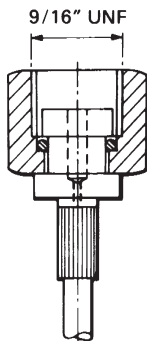

Code 9/16C

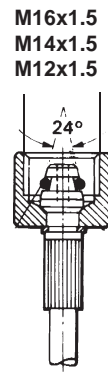

Code M16
Code M14
Code M12

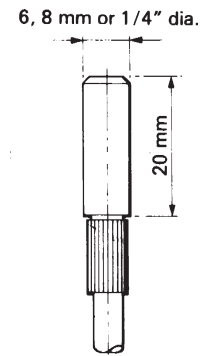

Code 6MSP
Code 8MSP
Code 4NSP

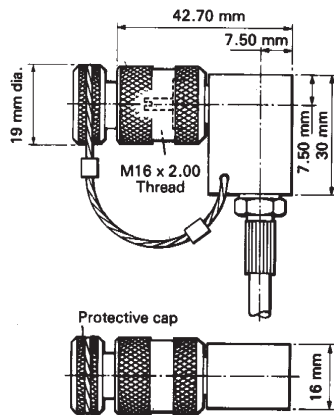

Code HSP-90

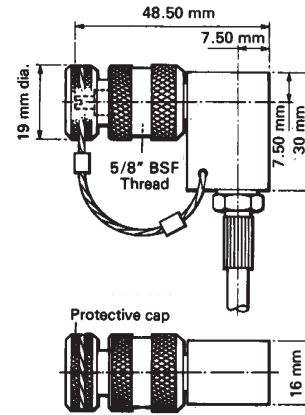

Code FTP-90

Section 3

HYDRAULIC VALVES

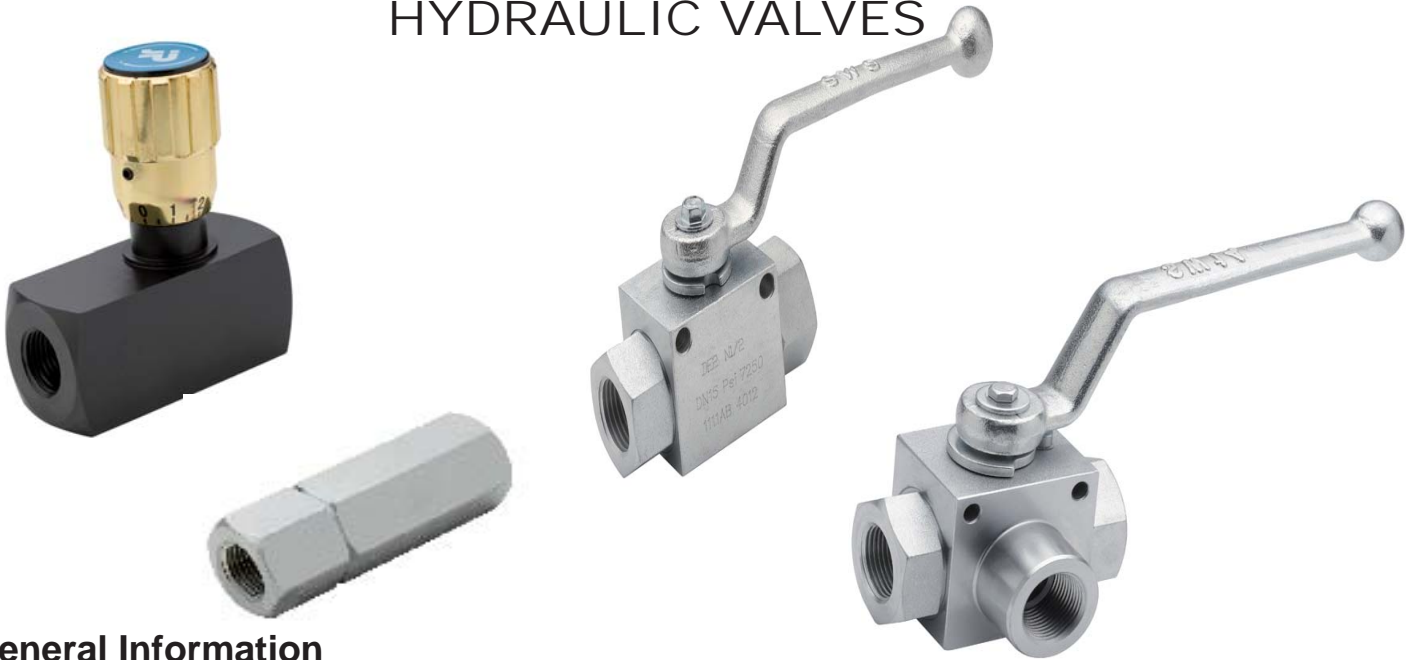

General Information

A range of new products have been added and inventoried for immediate delivery from our South Carolina and California warehouse. The new products include High and Low Pressure Ball Valves ¼ thru 2 inch port sizes. Also included is our Hard and Soft Seat Check Valves.

Table of Contents

<u>Product</u>	<u>Page No.</u>
Series DE2 High Pressure Ball Valves	21
Series DE3 High Pressure Ball Valves	22
Ball Valve Locking Handles	23
Series HSP Hard Seat Check Valves	24
Series VU Soft Seat Check Valves.....	24
Flow Control and Needle Valves	25-27

DE2/DB2 High Pressure Ball Valves

- Rugged Carbon Steel Construction
- Mounting holes standard
- 1/4" - 2" Sizes and SAE
- Up to 7000 PSI
- Blow-Out Proof Stems
- Various Seal Materials Available
- Full and Reduced Port

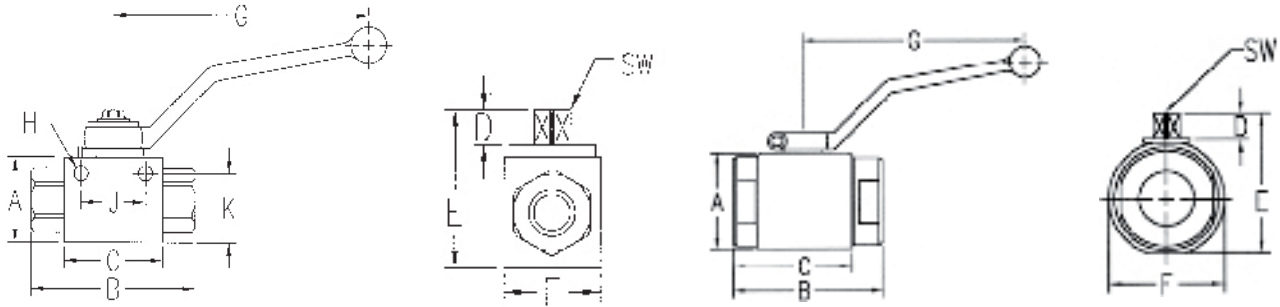

	Part Number	Thread	PSI	Port	A	B	C	D	E	F	G	H	J	K	SW
	DE2-14-NPT	1/4 NPT	7250	.24	1.38	2.79	1.65	.43	1.93	1.18	4.33	.19	1.02	.90	.35
	DE2-38-NPT	3/8 NPT	7250	.39	1.57	2.87	1.73	.43	2.12	1.38	4.33	.26	1.25	1.14	.35
	DE2-12-NPT	1/2 NPT	7250	.51	1.69	3.27	1.89	.43	2.24	1.45	4.33	.26	1.46	1.14	.35
	DE2-34-NPT	3/4 NPT	5800	.79	2.17	3.74	2.44	.51	2.87	1.77	7.08	.26	1.75	1.75	.55
	DE2-1-NPT	1 NPT	5000	.98	2.56	4.45	2.60	.51	3.26	2.16	7.08	.26	2.18	1.75	.55
Reduced Port	DE2-114R-NPT	1 1/4 NPT	5000	.98	2.56	4.76	2.60	.51	3.26	2.16	7.08	.26	2.18	2.05	.55
	DE2-112R-NPT	1 1/2 NPT	5000	.98	2.56	4.88	2.60	.51	3.26	2.16	7.08	.26	2.18	2.05	.55
Full Port	DB2-114-NPT	1 1/4 NPT	5000	1.26	3.25	4.53	3.74	.53	3.97	3.46	11.8	-	-	-	.67
	DB2-112-NPT	1 1/2 NPT	5000	1.57	3.86	5.15	4.25	.53	4.52	4.01	11.8	-	-	-	.67
	DB2-2-NPT	2 NPT	5000	1.97	4.05	5.51	4.72	.53	4.72	4.29	11.8	-	-	-	.67

	Part Number	Thread	PSI	Port	A	B	C	D	E	F	G	H	J	K	SW
Full Port	DE2-04-SAE	7/16-20	7250	.24	1.38	2.79	1.65	.43	1.93	1.18	4.33	.19	1.02	.90	.35
	DE2-06-SAE	9/16-18	7250	.39	1.57	2.87	1.73	.43	2.12	1.38	4.33	.26	1.25	1.14	.35
	DE2-08-SAE	3/4-16	7250	.51	1.69	3.27	1.89	.43	2.24	1.45	4.33	.26	1.46	1.14	.35
	DE2-12-SAE	1 1/16-12	5800	.79	2.17	3.74	2.44	.51	2.87	1.77	7.08	.26	1.75	1.75	.55
	DE2-16-SAE	1 5/16-12	5000	.98	2.56	4.45	2.60	.51	3.26	2.16	7.08	.26	2.18	1.75	.55
Reduced Port	DE2-20R-SAE	1 5/8-12	5000	.98	2.56	4.76	2.60	.51	3.26	2.16	7.08	.26	2.18	2.05	.55
	DE2-24R-SAE	1 7/8-12	5000	.98	2.56	4.88	2.60	.51	3.26	2.16	7.08	.26	2.18	2.05	.55
Full Port	DB2-20-SAE	1 5/8-12	5000	1.26	3.25	4.53	3.74	.53	3.97	3.46	11.8	-	-	-	.67
	DB2-24-SAE	1 7/8-12	5000	1.57	3.86	5.15	4.25	.53	4.52	4.01	11.8	-	-	-	.67
	DB2-32-SAE	2 1/2-12	5000	1.97	4.05	5.51	4.72	.53	4.72	4.29	11.8	-	-	-	.67

ALL DIMENSIONS IN INCHES

DE3L/DB3L 3 - Way High Pressure Ball Valves

- Rugged Carbon Steel Construction
- 1/4" - 2" Sizes
- Up to 4500 PSI
- Blow-Out Proof Stems
- Full and Reduced Port
- NPT and SAE Threads Available

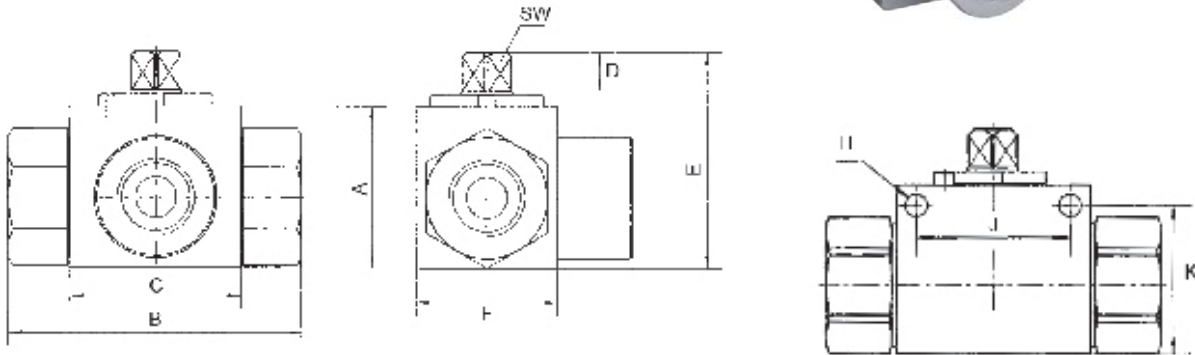

	Part Number	Thread	PSI	Port	A	B	C	D	E	F	H	J	K	SW
Full Port	DE3L-14-NPT	1/4 NPT	4500	.24	1.38	2.79	1.65	.43	1.93	1.18	.19	1.02	.90	.35
	DE3L-38-NPT	3/8 NPT	4500	.39	1.57	2.87	1.73	.43	2.12	1.38	.26	1.25	1.14	.35
	DE3L-12-NPT	1/2 NPT	4500	.51	1.69	3.27	1.89	.43	2.24	1.45	.26	1.46	1.14	.35
	DE3L-34-NPT	3/4 NPT	4500	.79	2.17	3.74	2.44	.51	2.87	1.77	.26	1.75	1.75	.55
	DE3L-1-NPT	1 NPT	4500	.98	2.56	4.45	2.60	.51	3.26	2.16	.26	2.18	1.75	.55
Reduced Port	DE3L-114R-NPT	1 1/4 NPT	4500	.98	2.56	4.76	2.60	.51	3.26	2.16	.26	2.18	2.05	.55
	DE3L-112R-NPT	1 1/2 NPT	4500	.98	2.56	4.88	2.60	.51	3.26	2.16	.26	2.18	2.05	.55
Full Port	DB3L-114-NPT	1 1/4 NPT	4500	1.26	3.25	4.53	3.74	.53	3.97	3.46	-	-	-	.67
	DB3L-112-NPT	1 1/2 NPT	4500	1.57	3.86	5.15	4.25	.53	4.52	4.01	-	-	-	.67
	DB3L-2-NPT	2 NPT	4500	1.97	4.05	5.51	4.52	.53	4.72	4.29	-	-	-	.67

	Part Number	Thread	PSI	Port	A	B	C	D	E	F	H	J	K	SW
Full Port	DE3L-04-SAE	7/16-20	4500	.24	1.38	2.79	1.65	.43	1.93	1.18	.19	1.02	.90	.35
	DE3L-06-SAE	9/16-18	4500	.39	1.57	2.87	1.73	.43	2.12	1.38	.26	1.25	1.14	.35
	DE3L-08-SAE	3/4-16	4500	.51	1.69	3.27	1.89	.43	2.24	1.45	.26	1.46	1.14	.35
	DE3L-12-SAE	1 1/16-12	4500	.79	2.17	3.74	2.44	.51	2.87	1.77	.26	1.75	1.75	.55
	DE3L-16-SAE	1 5/16-12	4500	.98	2.56	4.45	2.60	.51	3.26	2.16	.26	2.18	1.75	.55
Reduced Port	DE3L-20R-SAE	1 5/8-12	4500	.98	2.56	4.76	2.60	.51	3.26	2.16	.26	2.18	2.05	.55
	DE3L-24R-SAE	1 7/8-12	4500	.98	2.56	4.88	2.60	.53	3.26	2.16	.26	2.18	2.05	.55
Full Port	DB3L-20-SAE	1 5/8-12	4500	1.26	3.31	4.53	3.74	.53	3.97	3.46	-	-	-	.67
	DB3L-24-SAE	1 7/8-12	4500	1.57	3.86	5.15	4.25	.53	4.52	4.01	-	-	-	.67
	DB3L-32-SAE	2 1/2-12	4500	1.97	4.05	5.51	4.52	.55	4.72	4.29	-	-	-	.67

ALL DIMENSIONS IN INCHES

"L" PORT STANDARD, "T" PORT AVAILABLE. MINIMUM QTY. MAY APPLY

BALL VALVE ACCESSORIES

LOCKING KITS

PART NUMBER	DESCRIPTION
DLK-S	Handle Locking Kit For: 1/4" - 1/2" DE2 / DE3
DLK-M	Handle Locking Kit For: 3/4"-1 1/2", DE2 / DE3
DLK-MF	Handle Locking Kit For: 3/4" - 1" DE2 / DE3L
DLK-LF	Handle Locking Kit For: 1-1/4" - 1-1/2" DB2 / DB3L

CHECK VALVES Hard & Soft Seat

Model HSP - Hard Seat Carbon Steel Construction

5 lb or 65 lb Cracking Pressure Available



MODEL	A Size	B Inches	C Inches	Rated Flow gpm	Weight Lbs.	
HSP-1000-2-5 or 65	1/4 NPT	2.44	.87	6	.35	N P T
HSP-1000-3-5 or 65	3/8 NPT	2.87	1.00	10	.44	
HSP-1000-4-5 or 65	1/2 NPT	3.76	1.26	18	.77	
HSP-1000-6-5 or 65	3/4 NPT	4.30	1.50	30	1.54	
HSP-1000-8-5 or 65	1 NPT	5.12	1.69	36	2.43	
HSP-1000-10-5 or 65	1 1/4 NPT	5.56	2.40	50	6.95	
HSP-1000-12-5 or 65	1 1/2 NPT	5.56	2.56	60	7.28	S A E
HSP-1001-4-5 or 65	7/16-20 SAE	2.56	.87	6	.35	
HSP-1001-6-5 or 65	9/16-20 SAE	2.91	.94	10	.44	
HSP-1001-8-5 or 65	3/4-16 SAE	3.74	1.18	18	.77	
HSP-1001-12-5 or 65	1 1/6-12 SAE	4.29	1.50	30	1.54	
HSP-1001-16-5 or 65	1 5/16-12 SAE	5.00	1.81	36	2.43	
HSP-1001-20-5 or 65	1 5/8-12 SAE	5.20	2.41	50	6.95	
HSP-1001-24-5 or 65	1 7/8-12 SAE	5.20	2.56	60	7.28	

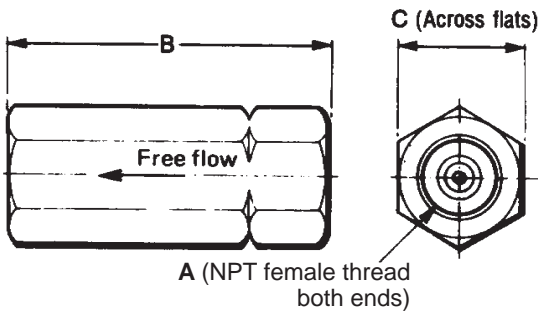

Rated Pressure: Sizes 2 thru 8 - 5000 psi
Sizes 10 thru 24 - 3000 psi

Model VU - Soft Seat

7 lb or 70 lb Cracking Pressure Available



MODEL	THREAD SIZE-NPT	A	B	RATED PRESSURE
VU-14F-7	1/4	1.96	.74	10,000 psi
VU-38F-7	3/8	2.36	.90	10,000 psi
VU-12F-7	1/2	2.76	1.06	7350 psi
VU-34F-7	3/4	3.38	1.38	7350 psi
VU-1F-7	1	3.93	2.16	7350 psi
VU-114F-7	1 1/4	5.12	1.97	4410 psi
VU-112F-7	1 1/2	5.31	2.56	4410 psi
VU-2F-7	2	5.91	2.95	4410 psi

Ordering Example: **VU** - **14F** - **7**

Dynamic Designation
VU - Soft Seat Model

Size - NPT
14F - 1/4
38F - 3/8
12F - 1/2
34F - 3/4
1F - 1
114F - 1 1/4
112F - 1 1/2
2F - 2

Cracking
7 - 7 psi
70 - 70 psi

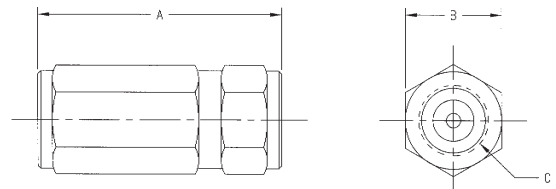



Features

Micrometer adjustment knob for accurate valve setting
Rugged construction

Technical Data

Materials: Body: Carbon steel with black oxide plating
Handle: Zinc Alloy
Set Screw: Steel
Packing: Buna O-Ring/PTFE stem packing

Maximum Pressure: 5000 PSI

Temperature Range: -4°F to 176°F (-20°C to 80°C)

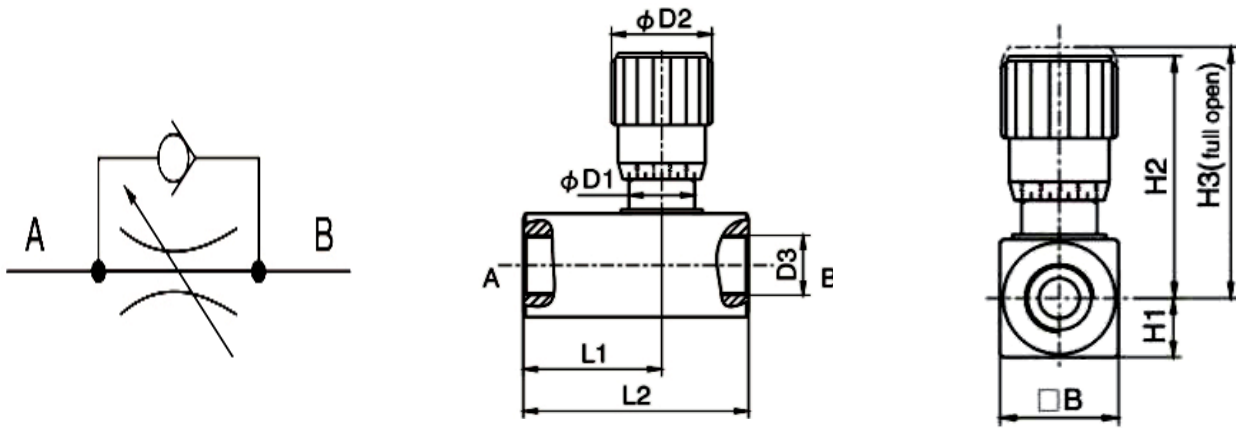

Ordering & Dimensional Information

Part Number	B	D1	D2	D3	H1	H2	H3	L1	L2	Weight
JP-FC-1/4-NPT-S	1.10	0.76	1.18	1/4 NPT	0.55	2.41	2.67	1.54	2.52	0.90 lbs
JP-FC-3/8-NPT-S	1.10	0.76	1.18	3/8 NPT	0.55	2.41	2.67	1.69	2.75	0.90 lbs
JP-FC-1/2-NPT-S	1.50	0.95	1.46	1/2 NPT	0.75	3.07	3.41	2.05	3.27	2.00 lbs
JP-FC-3/4-NPT-S	1.50	0.95	1.46	3/4 NPT	0.75	3.08	3.41	2.19	3.50	2.00 lbs
JP-FC-1-NPT-S	1.89	1.38	1.89	1 NPT	0.94	4.03	4.50	2.79	4.60	4.20 lbs
JP-FC-1 1/4-NPT-S	2.38	1.96	2.28	1 1/4 NPT	1.18	5.25	5.88	3.39	6.07	9.55 lbs
JP-FC-06-SAE-S	1.10	0.76	1.18	06 SAE	0.55	2.41	2.67	1.69	2.75	0.90 lbs



Features

Micrometer adjustment knob for accurate valve setting
Rugged construction

Technical Data

Materials: Body: Carbon steel with black oxide plating
Handle: Zinc Alloy
Set Screw: Steel
Packing: Buna O-Ring/PTFE stem packing

Maximum Pressure: 5000 PSI

Temperature Range: -4°F to 176°F (-20°C to 80°C)

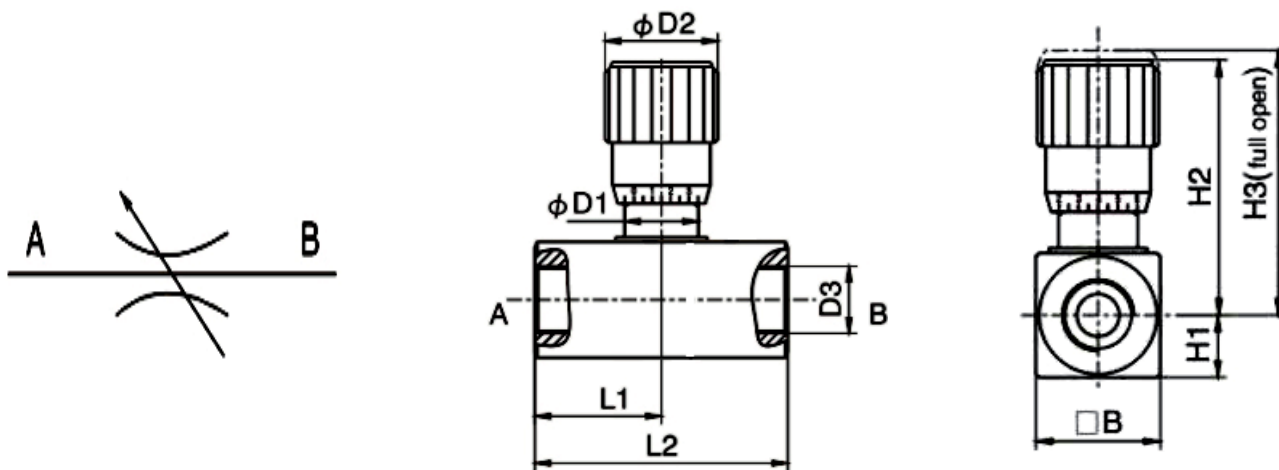

Ordering & Dimensional Information

Part Number	B	D1	D2	D3	H1	H2	H3	L1	L2	Weight
JP-NV-1/4-NPT-S	1.10	0.76	1.18	1/4 NPT	0.55	2.41	2.67	1.065	2.13	0.90 lbs
JP-NV-3/8-NPT-S	1.10	0.76	1.18	3/8 NPT	0.55	2.41	2.67	1.065	2.13	0.90 lbs
JP-NV-1/2-NPT-S	1.50	0.95	1.46	1/2 NPT	0.75	3.07	3.41	1.34	2.68	2.00 lbs
JP-NV-3/4-NPT-S	1.50	0.95	1.46	3/4 NPT	0.75	3.08	3.41	1.54	3.07	2.00 lbs
JP-NV-1-NPT-S	1.89	1.38	1.89	1 NPT	0.94	4.03	4.50	1.81	3.62	4.20 lbs
JP-NV-06-SAE-S	1.10	0.76	1.18	06 SAE	0.55	2.41	2.67	1.065	2.13	0.90 lbs

- Up to 10,000 PSI
- Heavy Duty construction for added strength and safety
- Carbon Steel valves are zinc plated and sealed with black chromate for corrosion protection
- Machined from carbon, 303 or 316 stainless steel
- Available in globe and angle configuration; in-line or panel mounted

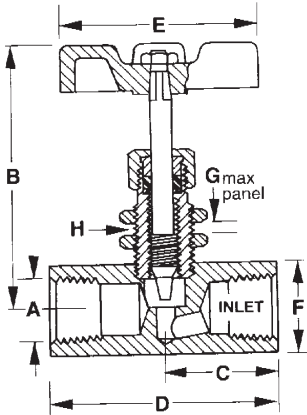

Performance

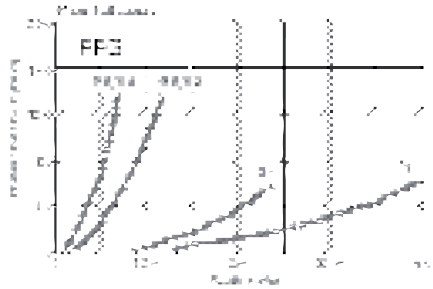

ORDERING INFORMATION

Part Number	Body Material	A (NPT) Female	B (In.) Max.	C (In.)	D (In.)	E (In.)	F (In.) Square	G (In.)	H (In.) Diam.	Orifice Diam. (In.)	CV	
DFFG2001T	Carbon Steel	1/8	3 1/2	31/32	1 15/16	2 1/2	7/8	3/8	5/8	7/22	.66	
DFFG2002T		1/4		1 1/32	2 1/16							
DFFG2003T		3/8	1 7/16	2 3/4	1 1/8		3/4		.70			
DFFG2004T		1/2	3 5/8	1 13/16	3 5/8	4 1/4	1 1/2	7/8	1 1/2	9/16	3.90	
DFFG2006TA		3/4	5 5/16	2 1/32	4 1/16	2	2	2	2	2	2	5.22
DFFG2008TA		1	5 5/16	2 1/32	4 1/16	4 1/4	2	2	2	2	2	5.22
DFFG2002SST	303 Stainless Steel	1/4	3 1/2	1 1/32	2 1/16	2 1/2	7/8	3/8	5/8	7/32	.66	
DFFG2003SST		3/8		1 7/16	2 3/4							1 1/8
DFFG2004SST		1/2	3 5/8	1 13/16	3 5/8		4 1/4		1 1/2		7/8	1 1/2
DFFG2006SSTA		3/4	5 3/16	1 13/16	3 5/8	4 1/4	1 1/2	7/8	1 1/2	9/16	3.90	
DFFG2008SSTA		1	5 5/16	2 1/32	4 1/16	4 1/4	2	2	2	2	2	5.22
DFFG2002SS6T	316 Stainless Steel	1/4	3 1/2	1 1/32	2 1/16	2 1/2	7/8	3/8	5/8	7/32	.66	
DFFG2004SS6T		1/2		1 7/16	2 3/4							1 1/8

Section 4

RESERVOIR ACCESSORIES



The limited range of competitively produced quality accessory products are detailed in the following pages. These hydraulic reservoir accessories are available from stock for immediate supply.

Table of Contents

<u>Product</u>	<u>Page No.</u>
DB Series Breathers.....	29
DFB Series Filter Filler Breathers.....	30

Screw-On Type Air Breathers

CHROME PLATED STEEL

- 1/4 to 1 Inch NPT
- Steel Model
- 40 Micron Breather

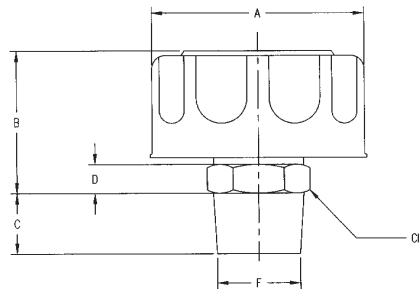

Model	Flow cfm	NPT	A	B	C	D	CH	Micron
DB40-04	10	1/4	1.85	1.60	.50	.30	.63	40
DB40-06	10	3/8	1.85	1.70	.50	.30	.75	40
DB40-08	10	1/2	2.54	1.88	.68	.29	.95	40
DB40-12	25	3/4	3.13	2.00	.82	.35	1.12	40
DB40-16	25	1	3.13	2.11	.90	.42	1.35	40

Filter Filler Breathers

- Chrome Plated Cap
- 40 Micron Breather
- 3½" & 6" Basket Length
- Lockable Options
- Plastic Basket Standard

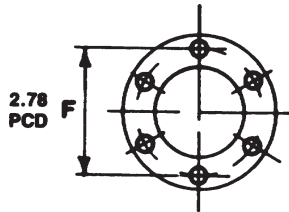
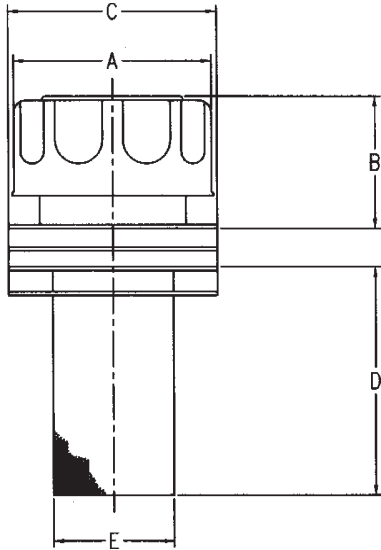

STYLE	A	B	C	D
DFB	2.95	1.97	1.97	1.97

Ordering Example:

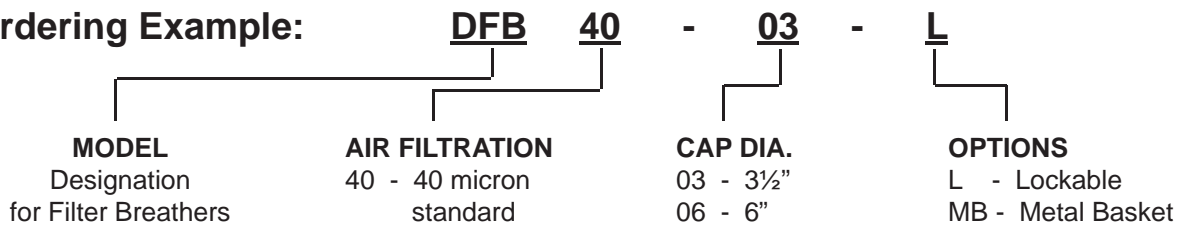

* Consult Factory for ordering caps or baskets only



FLUID COMPONENTS, INC.

METRIC CONVERSIONS

PRESSURES

Common catalog PRESSURES and corresponding value in bar, kilopascals and kilograms per square inch.

PSI	Bar	kPa	kg/cm ²
0.5	0.034	3.44	0.0352
1	0.069	6.89	0.0703
1.25	0.086	8.62	0.0879
2	0.138	13.79	0.1406
5	0.345	34.48	0.3515
10	0.699	69.85	0.7030
15	1.034	103.43	1.0545
20	1.379	137.90	1.4060
25	1.724	172.38	1.7500
30	20.69	206.85	2.1090
35	2.413	241.33	2.4605
40	2.758	275.80	2.8120
50	3.448	344.75	3.5150
60	4.137	413.70	4.2180
70	4.827	482.65	4.9210
80	5.516	551.60	5.6240
90	6.206	620.55	6.3270
100	6.895	689.50	7.0300
125	8.619	861.88	8.7875
150	10.343	1034.25	10.5450
175	12.066	1206.63	12.3025
200	13.790	1379.00	14.0600
250	17.238	1723.75	17.5750
275	18.961	1896.13	19.3325
300	20.685	2068.50	21.0900
350	24.133	2413.25	24.6050
400	27.580	2758.00	28.1200
500	34.475	3447.50	35.1500
600	41.370	4137.00	42.1800
750	51.713	5171.25	52.7250
1000	68.950	6895.00	70.3000
1500	103.425	10342.50	105.4500
1900	131.005	13100.50	133.5700
2200	151.690	15169.00	154.6600

COMMON EQUIVALENTS

Common English Unit and how to obtain the International Organization of Standardization (ISO) equivalent unit.

English Unit	Multiply by	To Obtain ISO Unit
Gallon (U.S. liquid)	3.785	liter (l)
Foot ³	0.02832	meter ³ (m)
Ounce	28.35	gram (g)
Pound	0.4536	kilogram (kg)
Inch	25.40	millimeter (mm)
Foot	0.3048	meter (m)
PSIG	0.06895	bar
Inches of Water	0.00249	bar
Inches of Mercury	0.03386	bar
PSIG	6.895	kilopascal (kPa)
Inches of Water	0.249	kilopascal (kPa)
Inches of Mercury	3.386	kilopascal (kPa)
Std. cubic feet/hour (SCFH)	0.00786	cubic decimeter normalized/sec (dm ³ /s)
Gallons/minute (GPM)	3.785	liters/minute (l/min)

COMMON EQUIVALENTS

Common catalog ORIFICE sizes and ISO equivalents in mm.

Inches	mm	Inches	mm
3/64 (.0469)	1.19	7/16 (.4375)	11.11
1/16 (.0625)	1.59	1/2 (.5000)	12.70
5/64 (.0781)	1.98	5/8 (.6250)	15.88
3/32 (.0937)	2.38	11/16 (.6875)	17.46
1/8 (.1250)	3.18	3/4 (.7500)	19.05
5/32 (.1562)	3.97	1 (1.000)	25.40
11/64 (.1719)	4.37	1 1/8 (1.125)	28.58
3/16 (.1875)	4.76	1 1/4 (1.250)	31.75
7/32 (.2187)	5.55	1 1/2 (1.500)	38.10
1/4 (.2500)	6.35	1 3/4 (1.750)	44.45
9/32 (.2812)	7.14	2 (2.000)	50.80
5/16 (.3125)	7.94	3 (3.000)	76.20

SUGGESTED PRODUCT COMPATIBILITY GUIDE

Bronze

acetone	butanol	cuprous oxide	ethylene glycol	glycerine	oil (lubricating)	sea water
acetylene	butyric acid	dextrine	eucalyptol	kerosene	oil (refined)	tanning liquors
alcohol	calcium chloride	ethers	formaldehyde	lacquers	oxygen	toluene
beer	calcium hydroxide	ethyl acetate	freon	lysol	paraffin	water
benzine	carbon dioxide (dry)	ethyl cellulose	gallic acid	magnesium sulfate	potassium chloride	whiskey
benzol	casein	ethylene	gas, illuminating	methyl salicylate	prestone	
bordeaux mixture	chloroform	ethylene dibromide	gasoline	naphtha	proxylin	
butane	coal gas	ethylene dichloride	glucose	nickel acetate	salicylic acid	

Steel

acetone	ammonium	calcium hydroxide	ethers	magnesium sulfate	sodium carbonate	sulfur dioxide (dry)
acetylene	phosphate	carbon bisulfide	gasoline (refined)	mercury	sodium hydroxide	sulfuric (concentrated to 75%)
alcohol	benzine	carbon dioxide (dry)	glucose	methyl chloride	sodium nitrate	toluene
ammonium	benzol	chloroform	glycerine	pitric acid (dry)	sodium sulfate	vegetable oils
carbonate	benzyl alcohol	coal gas	derosene	potassium chloride	sodium sulfite	
ammonium	butane	cottonseed oil	magnesium	potassium cyanide	sodium sulfite	
hydroxide	butanol	creosole (crude)	hydroxide	potassium sulfate	sulfur dioxide (dry)	

316 Stainless Steel

acetic acid	butane	ferric nitrate	lox	photographic	silver nitrate	vinegar
acetic anhydride	calcium bisulfite	ferric sulfate	nitric acid (pure)	solutions	sodium cyanide	vegetable oils
alums	carbon disulfide	hydrocyanic acid	nitrous acid	pickling solutions	sodium peroxide	wines
aluminum sulfate	chromic acid	hydrogen	nitrous oxide	pitric acid	sodium phosphate	
ammonia	citric acid	hydrogen peroxide	oxygen	potassium	sulfur dioxide	
bleach liquors	copper sulfate	lactic acid	phosphoric acid	permangante	sulfurous acid	